

RM4-TMR

DIN Rail Mount
Timer

Process Monitor/Controller
Operation and Instruction Manual



Table of Contents

Introduction	3
Entry to setup and scaling functions	4
Mechanical installation	5
Electrical installation	6
Power supply connections	7
Relay connections	7
Reset, start & stop input	7
Remote input connections	7
Transducer power supply	8
Signal input connections	9
Configuring the input board	11
Input link settings	11
Period measurement	12
Explanation of functions	13
Period measurement examples	19
Function table - period mode	20
Scaled period measurement	21
Explanation of functions	21
Scaled period measurement examples	26
Function table - scaled period mode	28
Specifications	29
Technical Specifications	29
Output Options	29
Physical Characteristics	29
Guarantee and Service	30

1 Introduction

This manual contains information for the installation and operation of the RM4-TMR Timer Monitor. The instrument may be set to operate in one of two basic modes namely period (*PEFd*) or scaled period (*S.Prd*) modes. The mode of operation is selected at the *SEt OPEr* function.

The two modes of operation are:

***PEFd* - period of the input pulse display.** The period of the input pulse is measured and may be displayed in any one of 8 different time display modes (e.g. hours.minutes.seconds). Count up from zero or count down from a preset value modes of operation are provided. Period measurement functions are described in chapter 4.

***S.Prd* - scaled period display mode.** This mode allows the measurement and scaling of the duration of an input pulse. Since time is being measured the display would typically be programmed and scaled to read in time (seconds, milli seconds etc.) or rate (metres/second, litres/hour etc.). It is equally valid to scale the display to read in any units which may be a function of time e.g. distance travelled in mm. Scaled period measurement functions are described in chapter 5.

Selection of operating mode, calibration and scaling are all accomplished by push button operation. "On screen" prompts are given for each function to assist in setting up the instrument. Some changes may require dismantling the instrument to alter PCB links.

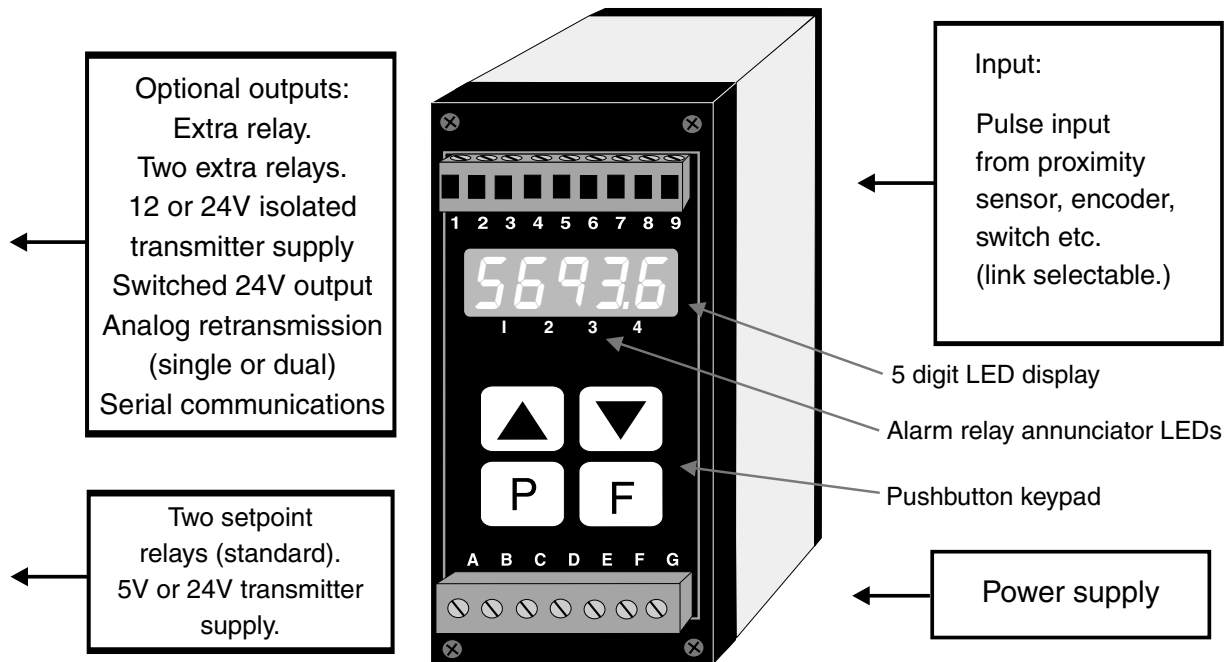

1.1 Entry to setup and scaling functions

The RM4 setup and calibration functions are configured through a push button sequence (see also **RECS** function). Two levels of access are provided for setting up and calibrating:-

FUNC mode (simple push button sequence) allows access to alarm relay, preset value & display brightness functions. **CAL** mode (power up sequence plus push button sequence) allows access to all functions including calibration parameters.

Push buttons located at the front of the instrument are used to alter settings. Once **CAL** or **FUNC** mode has been entered you can step through the functions, by pressing and releasing the **F** push button, until the required function is reached. Changes to functions are made by pressing the **▲** or **▼** push button (in some cases both simultaneously) when the required function is reached.

Entering **CAL** Mode



1. Remove power from the instrument. Hold in the **F** button and reapply power. The display will indicate **CAL** as part of the "wake up messages" when the **CAL** message is seen you can release the button.



2. When the "wake up" messages have finished and the display has settled down to its normal reading press, then release the **F** button.

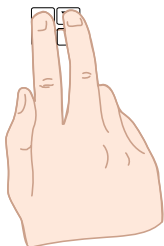

3. Within 2 seconds of releasing the **F** button press, then release the **▲** and **▼** buttons together. The display will now indicate **FUNC** followed by the first function.

Entering **FUNC** Mode

No special power up procedure is required to enter **FUNC** mode.



1. When the "wake up" messages have finished and the display has settled down to its normal reading press, then release the **F** button.

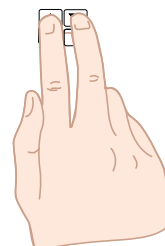

2. Within 2 seconds of releasing the **F** button press, then release the **▲** and **▼** buttons together. The display will now indicate **FUNC** followed by the first function.

Note: If step 1 above has been completed then the instrument will remain in this **CAL** mode state until power is removed. i.e. there is no need to repeat step 1 when accessing function unless power has been removed.

2 Mechanical installation

The RM4 is designed for DIN rail, horizontal mounting. The instrument snaps on 35mm DIN standard rails (EN50022). Cut the DIN rail to length and install where required. To install the RM4, simply clip onto the rail as shown below. To remove the RM4 lever the lower arm downwards using a broad bladed screwdriver to pull the clip away from the DIN rail.

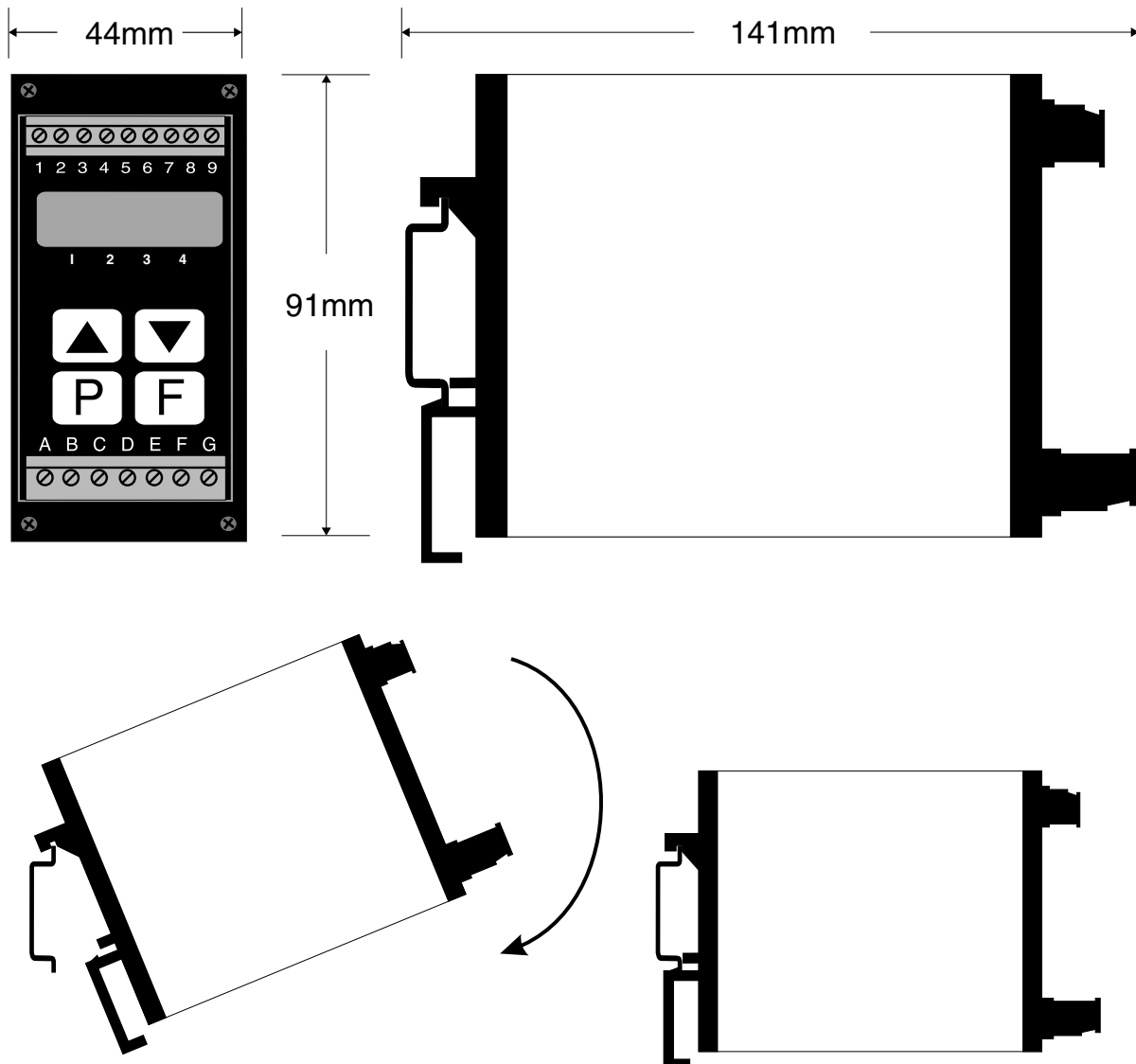

3 Electrical installation

The RM4 Meter is designed for continuous operation and no power switch is fitted to the unit. It is recommended that an external switch and fuse be provided to allow the unit to be removed for servicing.

The terminal blocks allow for wires of up to 2.5mm² to be fitted for power supply and relays 1 and 2 or 1.5mm² for input signal connections and optional outputs. Connect the wires to the appropriate terminals as indicated below. Refer to other details provided in this manual to confirm proper selection of voltage, polarity and input type before applying power to the instrument. When power is applied the instrument will cycle through a display sequence, indicating the software version and other status information, this indicates that the instrument is functioning. Acknowledgement of correct operation may be obtained by applying an appropriate input to the instrument and observing the resultant reading.

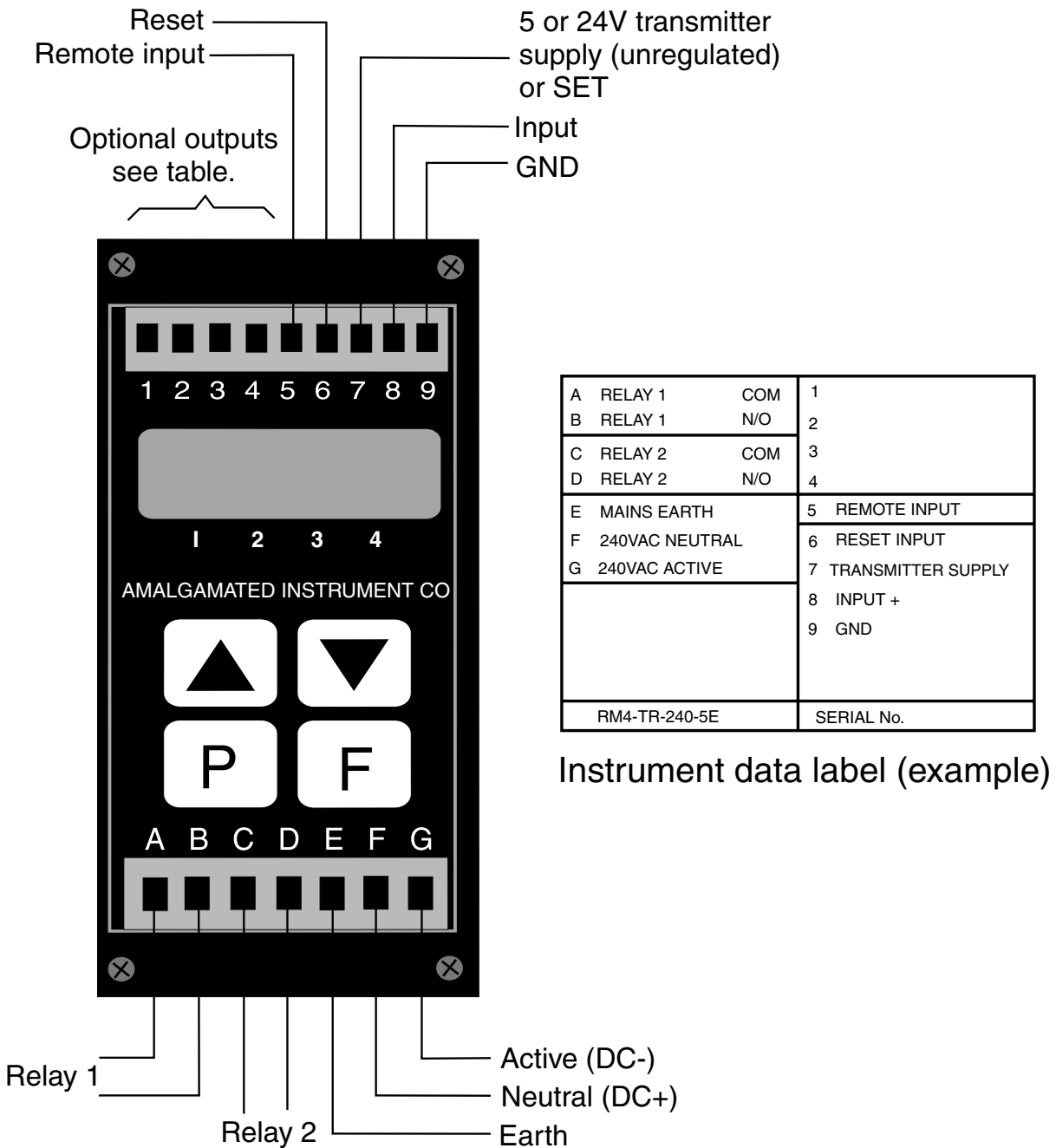

3.1 Power supply connections

The power supply for the instrument is factory fitted and is of a fixed type. If you are unsure of the supply requirement for your instrument it can be determined by the model number on the instrument label:-

RM4-TR-240-.....	Requires 240VAC
RM4-TR-110-.....	Requires 110VAC
RM4-TR-32-.....	Requires 32VAC
RM4-TR-24-.....	Requires 24VAC
RM4-TR-DC-.....	Requires between 12 and 48VDC

3.2 Relay connections

The RM4 is supplied with two alarm relays as standard Relay 1 is connected across terminals A and B, Relays 2 is connected across terminals C and D. One or two extra relays are optionally available. Relays 1 & 2 are single pole, single throw types (form A) and are rated at 5A, 240VAC into a resistive load Relays 3 and 4 are form A rated 0.5A resistive 30VAC or DC. The relay contacts are voltage free and may be programmed for normally open or normally closed operation. If only 3 relays are fitted and no other options are fitted then Relay 3 can be configured as form C.

3.3 Reset, start & stop input

Input for the various operation modes are shown below. The operation mode is selected at the **OPER** function.

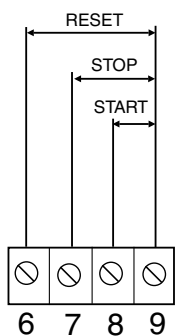

Input connections for **UP** and **dn** operation modes

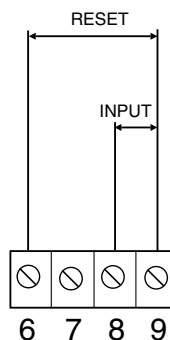

Input connections for **run**, **SngL**, **Sng.H**, **A.dur** and **Sng.F** operation modes

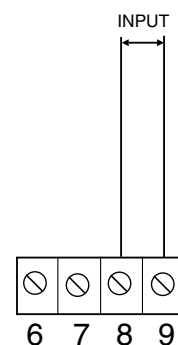

Input connections for **dur**, **PLSE**, **PLS.H** and **PLS.F** operation modes

3.4 Remote input connections

The selected remote input function can be operated via an external contact closure via a switch, relay or open collector transistor switch.

A momentary action is required for functions such as **LAPE** and **ZERO**, a latching switch or normally closed momentary switch may be required for functions such as peak hold.

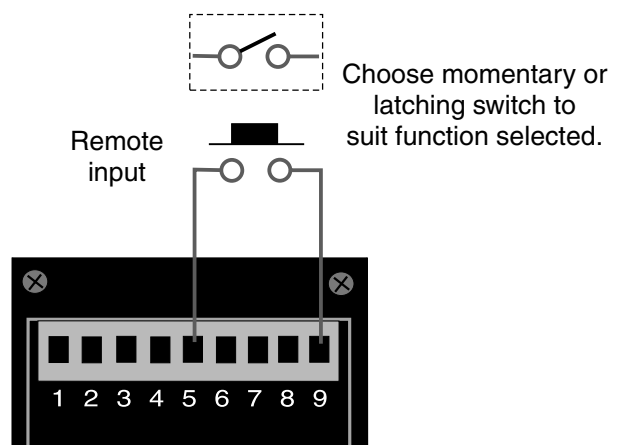

3.5 Transducer power supply

The standard internal dc power supply may be link selected to provide a regulated 5V or unregulated 5V or 24V to power the sensor, the maximum current available is 25mA. The optional isolated & regulated supply can be link selected to provide either 12V @ 50mA max. or 24V @ 25mA.

3 wire externally powered.

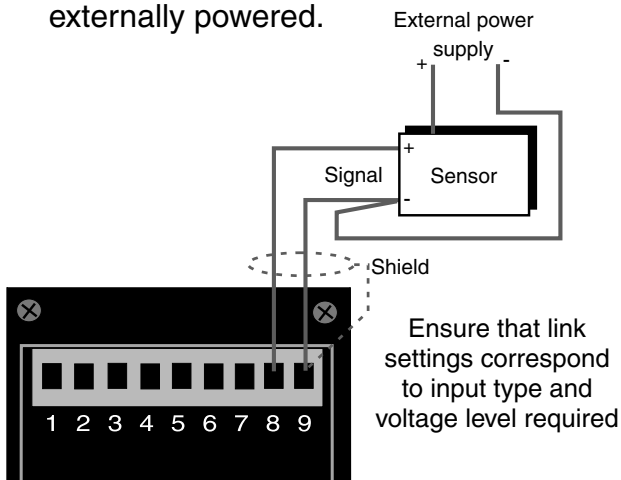

4 wire sensor powered via standard 5V or 24V unregulated.

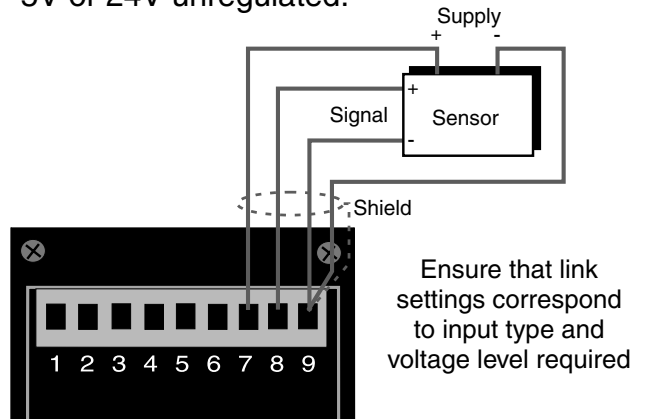

3 wire sensor powered via standard 5V or 24V unregulated.

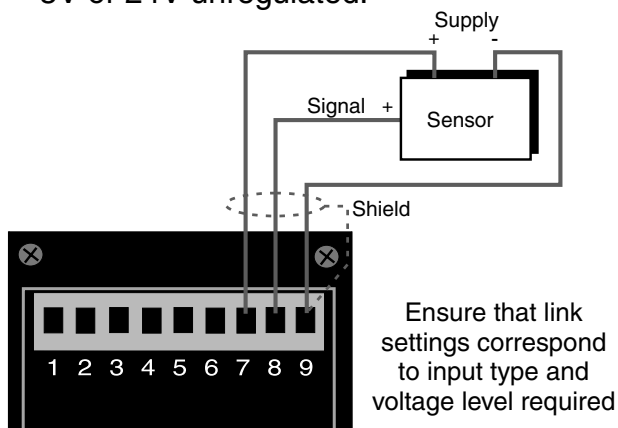

3 wire sensor powered via optional 12 or 24V regulated.

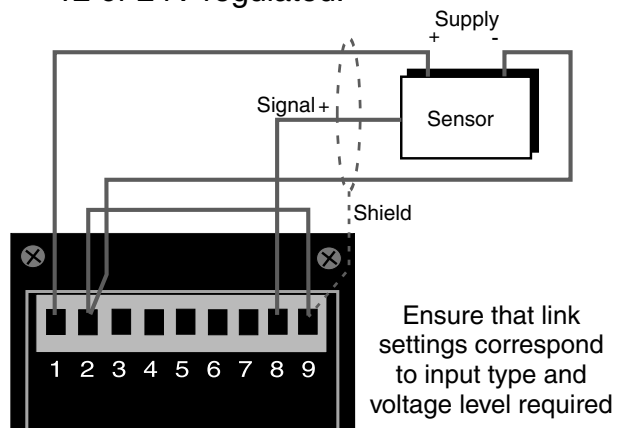

3.6 Signal input connections

INDUCTIVE SENSOR

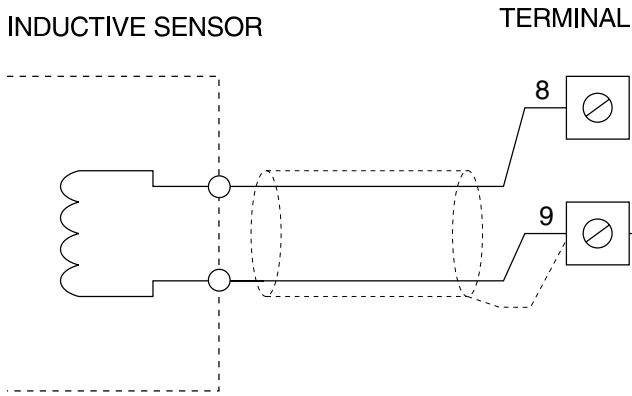

Inductive Sensor (48V RMS Max)

Typical Internal Link Settings

FREQ	Link LK1	in or out *
BIAS	Link LK2	out
DC	Link LK3	in
HYST	Link LK4	in or out *
HYST2	Link LK5	in or out *
GND	Link LK6	in or out *
LOW FREQ	Link LK7	out
AC	Link LK8	out
VCC	Link LK9	out

* See "Input link settings, section 3.8".

AC MEASUREMENT

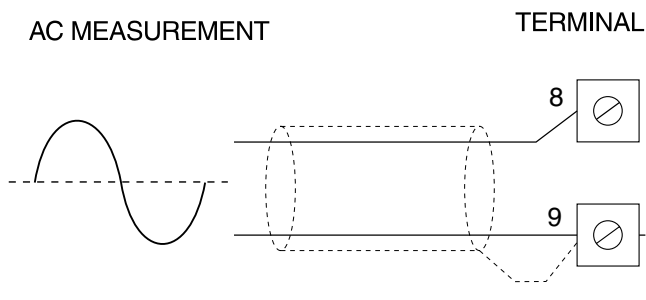

AC Measurement (48V RMS Max)

Typical Internal Link Settings

FREQ	Link LK1	in or out *
BIAS	Link LK2	out
DC	Link LK3	in or out *
HYST	Link LK4	in or out *
HYST2	Link LK5	in or out *
GND	Link LK6	in or out *
LOW FREQ	Link LK7	out
AC	Link LK8	out
VCC	Link LK9	out

* See "Input link settings, section 3.8".

SQUARE WAVE INPUT

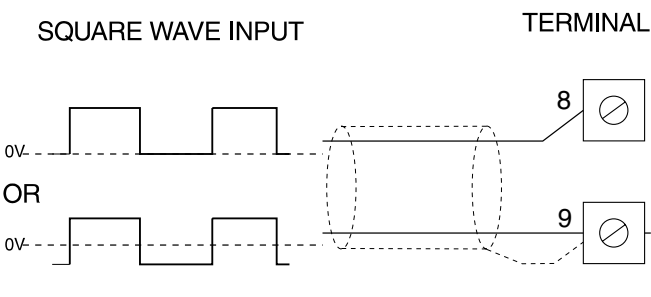

Square wave (48V Max)

Typical Internal Link Settings

FREQ	Link LK1	out
BIAS	Link LK2	in or out *
DC	Link LK3	in
HYST	Link LK4	in or out *
HYST2	Link LK5	in or out *
GND	Link LK6	in or out *
LOW FREQ	Link LK7	out
AC	Link LK8	out
VCC	Link LK9	out

* See "Input link settings, section 3.8".

CONTACT CLOSURE

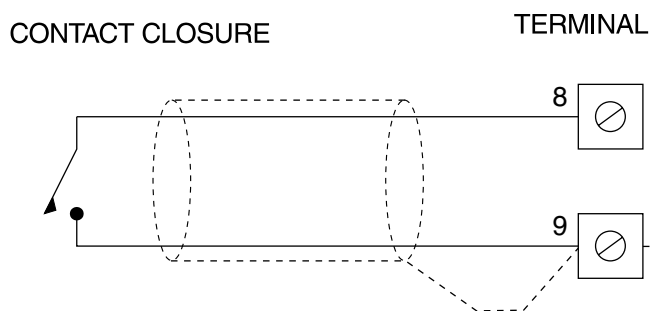

Voltage free contact

Typical Internal Link Settings

FREQ	Link LK1	out
BIAS	Link LK2	in
DC	Link LK3	in
HYST	Link LK4	in
HYST2	Link LK5	out
GND	Link LK6	out
LOW FREQ	Link LK7	in
AC	Link LK8	out
VCC	Link LK9	in

* See "Input link settings, section 3.8".

NAMUR SENSOR

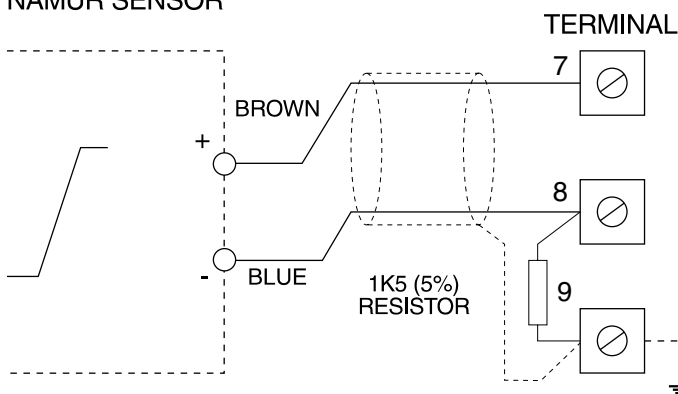

Namur sensor

Typical Internal Link Settings

FREQ	Link LK1	out
BIAS	Link LK2	in
DC	Link LK3	in
HYST	Link LK4	in
HYST2	Link LK5	out
GND	Link LK6	in
LOW FREQ	Link LK7	out
AC	Link LK8	out
VCC	Link LK9	out

* See "Input link settings, section 3.8".

NPN TRANSISTOR

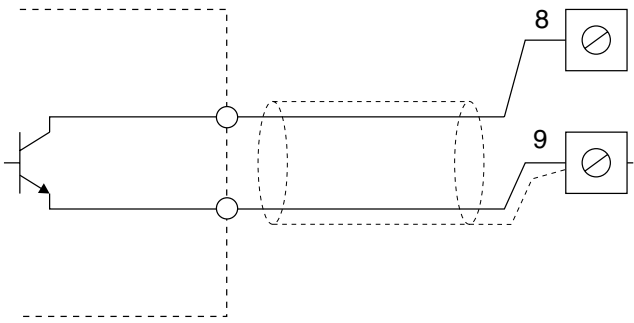

NPN transistor sensor

Typical Internal Link Settings

FREQ	Link LK1	out
BIAS	Link LK2	in
DC	Link LK3	in
HYST	Link LK4	in or out *
HYST2	Link LK5	in or out *
GND	Link LK6	out
LOW FREQ	Link LK7	out
AC	Link LK8	out
VCC	Link LK9	in

* See "Input link settings, section 3.8".

Note: the transducer may require an external DC supply. This may be provided from a remote power source, by a DC output on terminal 7 or optional isolated DC supply (see "Transducer power supply").

NPN TRANSISTOR 3 WIRE

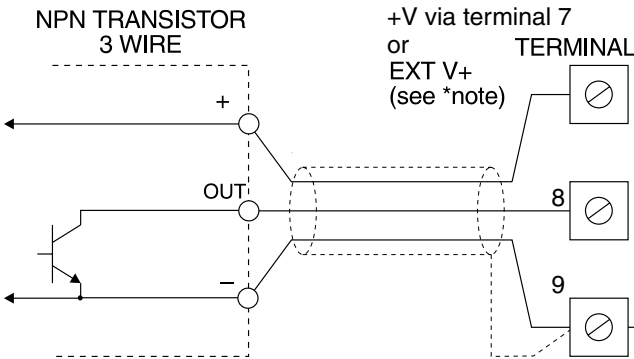

3 wire NPN transistor sensor

Typical Internal Link Settings

FREQ	Link LK1	out
BIAS	Link LK2	in
DC	Link LK3	in
HYST	Link LK4	in or out *
HYST2	Link LK5	in or out *
GND	Link LK6	out
LOW FREQ	Link LK7	out
AC	Link LK8	out
VCC	Link LK9	in

* See "Input link settings, section 3.8".

Note: the transducer may require an external DC supply. This may be provided from a remote power source, by a DC output on terminal 7 or optional isolated DC supply (see "Transducer power supply").

PNP TRANSISTOR

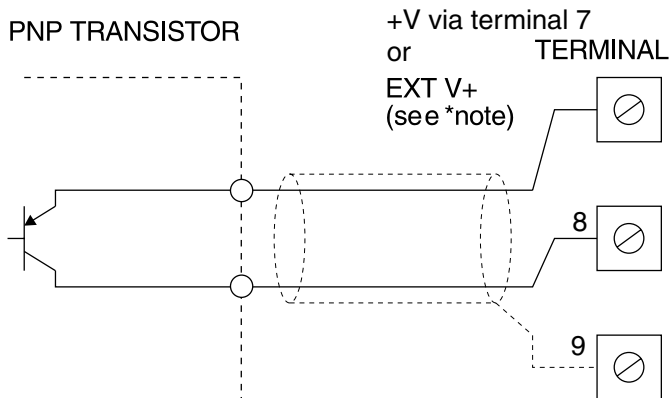

PNP transistor sensor

Typical Internal Link Settings

FREQ	Link LK1	out
BIAS	Link LK2	in
DC	Link LK3	in
HYST	Link LK4	in or out *
HYST2	Link LK5	in or out *
GND	Link LK6	out
LOW FREQ	Link LK7	in
AC	Link LK8	out
VCC	Link LK9	out

* See "Input link settings, section 3.8".

Note: the transducer may require an external DC supply. This may be provided from a remote power source, by a DC output on terminal 7 or optional isolated DC supply (see "Transducer power supply").

PNP TRANSISTOR 3 WIRE

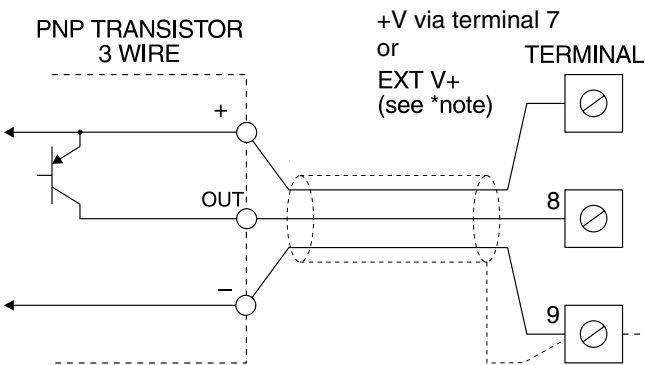

3 wire PNP transistor sensor

Typical Internal Link Settings

FREQ	Link LK1	out
BIAS	Link LK2	in
DC	Link LK3	in
HYST	Link LK4	in or out *
HYST2	Link LK5	in or out *
GND	Link LK6	in
LOW FREQ	Link LK7	out
AC	Link LK8	out
VCC	Link LK9	out

* See "Input link settings, section 3.8".

Note: the transducer may require an external DC supply. This may be provided from a remote power source, by a DC output on terminal 7 or optional isolated DC supply (see "Transducer power supply").

3.7 Configuring the input board

Remove the circuit board from the case following the instructions below.

Remove the connectors, the four front bezel screws and the earth screw at the side of the case. Hold the front bezel and slide out the circuit boards.

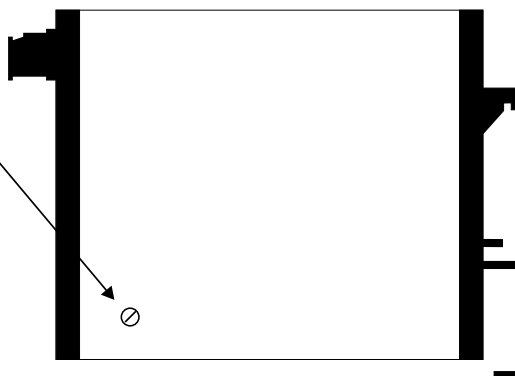

Link settings for the main input boards are as shown below. For optional output link settings consult the appropriate appendix in this manual.

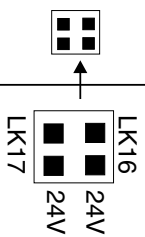
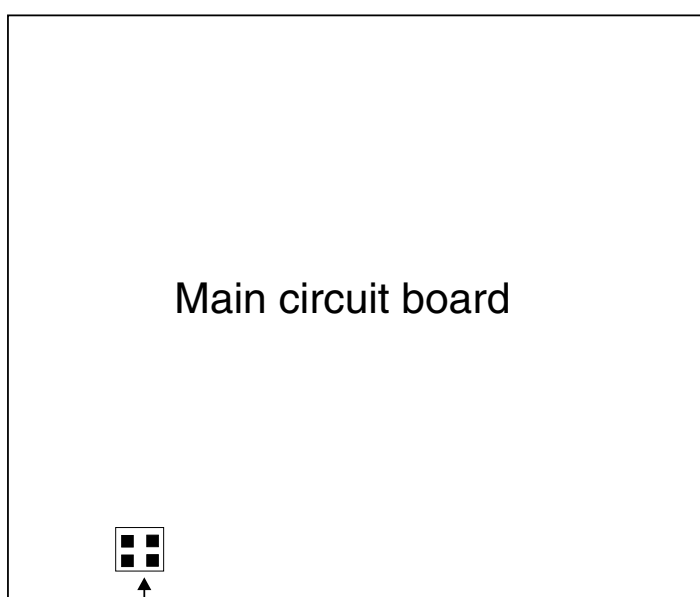

LK16 and 17 in for 24VDC transmitter supply on terminal 7. Note: If terminal 7 is to be used as a 5VDC transmitter supply or as a "SET" input then LK16 and 17 must be out.

See section 3.7 for details of link setting requirements for links LK1 to LK9.

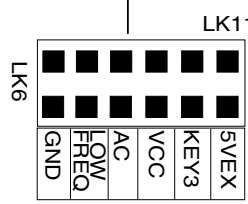
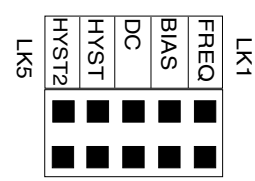
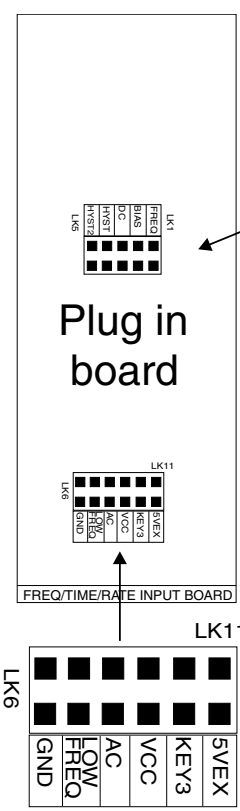

LK11 "5VEX" link is in for 5VDC transmitter supply on terminal 7. LK10 "KEY3" is in if terminal 7 is to be used as the "SET" input. Note: if terminal 10 is in then link 11 must be out.

3.8 Input link settings

The **LOW FREQ** link LK7 is primarily provided to filter out contact bounce for voltage free inputs. It can also be used to filter out frequencies above approx. 80Hz in electrically noisy environments when the maximum input frequency is less than approx. 80Hz.

The **GND** link LK6 and **VCC** link LK9 should both be out when the input is greater than 24V RMS or 24VDC (48V RMS or 48VDC max. with links removed).

HYST2 link LK5 should be in for signals greater than 1V. **HYST** link LK4 should be in for signals greater than 5V. For signals lower than 1V both links should be out (100mV minimum signal). A maximum of one hysteresis link should be fitted.

The **DC** coupling link LK3 should be in for frequencies less than 10Hz.

The **BIAS** link LK2 should be in when input signal does not go below 0V.

The **FREQ** link LK1 is used to create a sharply rising edge to give a more definite pulse signal and will be used mainly for input signals with slowly rising edges, typically sinewave AC inputs and inductive inputs.

4 Period measurement

The period mode operation is used when a display of the actual time period of the input pulse is required (with no scaling). Eight different period display options are given, from a display in seconds to a display in hours. These display options may be selected at the **di SP RANGE** function. You will also need to choose the required operation mode from the **OPER** function. There are 8 different operation modes to choose from, allowing a wide choice of timing methods.

The instrument will measure the period of the pulse width from either the low or high going edge of the pulse, selection of which edge to start measurement from is via the **i NPt** function.

Period measurement

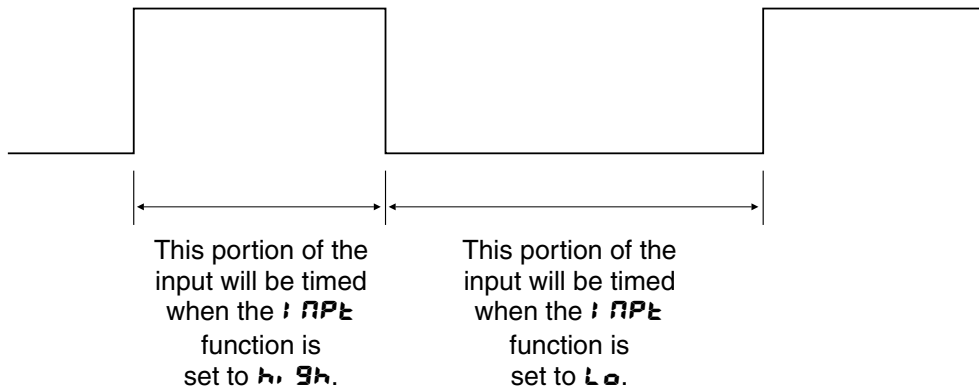

Note: this model will time the low **or** the high period of the waveform, not the overall period. Alternative stopwatch type operations (**OPER** function set to **UP** or **dn**) allow separate start, stop and reset inputs.

For inputs such as relays with contact bounce problems which may lead to unstable readings, it may be useful to use the debounce (**dbnc**) function to filter out the contact bounce.

Remember that you will need to enter via **CAL** or **FUNC** mode (see section 1.1) to gain access to functions, the function table for each mode shows which functions require entry via **CAL** mode.

Note: a number relays are available with certain option combinations (a maximum of 4 relays may be fitted to the RM4-TMR if no other options such as retransmission are required), the alarm functions are displayed only for the actual number of relays provided. The "x" shown in the following display messages represents the alarm number i.e. **RxLo** as shown in the text will appear as **R1Lo**, **R2Lo** etc. on the instrument display.



The RM4-TMR has an easy alarm access facility which allows access to the alarm setpoints simply by pressing the **F** button at the front or rear of the instrument. The first setpoint will then appear and changes to this setpoint may be made to this setpoint via the **▲** or **▼** buttons. Press the **F** button to accept any changes or to move on to the next setpoint.

The instrument must be set in the manner described below in order for the easy access to work:



1. The **i NP** function must be set to **SP.RC**.
2. At least one alarm must have a setpoint, nothing will happen if all the alarm setpoints are set to **OFF**.
3. The **SP.RC** function must be set to allow access to the relays required e.g. if set to **R 1-2** then the easy access will work only with alarm relays 1 and 2 even if more relays are fitted.
4. The instrument must be in normal measure mode i.e. if the instrument is powered up so that it is in **CAL** mode then the easy access will not function. If in doubt then remove power from the instrument, wait for a few seconds then apply power again.
5. If the easy access facility is used then the only way to view or alter any other function settings is to power up via **CAL** mode i.e. there is not entry to **FUNC** mode unless the instrument is powered up in **CAL** mode.

4.1 Explanation of functions

RxLo (alarm low setpoint)

Displays and sets the alarm low setpoint value for the designated alarm relay. The low alarm setpoint may be disabled by pressing the  and  pushbuttons simultaneously. When the alarm is disabled the display will indicate **OFF**. The alarm relay will trip when the displayed value is less than the **RxLo** setpoint value. Relays may be configured with both a low and high setpoint, so the relay may be tripped when the reading moves outside the band set between low and high. e.g. if **R1Lo** is set to **10.0** and **R1Hi** is set to **90.0** then the alarm output relay will trip when the display value either goes below **10.0** or goes above **90.0**.

RxHi (alarm high setpoint)

Displays and sets the alarm high setpoint value for the designated alarm relay. The high alarm setpoint may be disabled by pressing the  and  pushbuttons simultaneously. When the alarm is disabled the display will indicate **OFF**. The alarm relay will trip when the displayed value is greater than the **RxHi** setpoint value. Relays may be configured with both a low and high setpoint, so the relay may be tripped when the reading moves outside the band set between low and high (see **RxLo** for example).

RxHy (alarm hysteresis [deadband])

Displays and sets the alarm hysteresis limit and is common for both high and low setpoint values. The hysteresis value may be used to prevent too frequent operation of the alarm relay when the measured value stays close to the setpoint. Without a hysteresis setting (**RxHy** set to zero) the alarm will trip when the display value goes above the alarm setpoint (for high alarm) and will reset when the display value falls below the setpoint, this can result in repeated on/off switching of the relay at around the setpoint value. The hysteresis setting operates as follows:

In the high alarm mode, once the alarm is tripped the input must fall below the setpoint value minus the hysteresis value to reset the alarm.

e.g. if **R1Hi** is set to **50.0** and **R1Hy** is set to **3.0** then the alarm output relay will trip once the display value goes above **50.0** and will reset when the display value goes below **47.0** (50.0 minus 3.0).

In the low alarm mode, once the alarm is tripped the input must rise above the setpoint value plus the hysteresis value to reset the alarm.

e.g. if **R1Lo** is set to **20.0** and **R1Hy** is set to **10.0** then the alarm output relay will trip when the display value falls below **20.0** and will reset when the display value goes above **30.0** (20.0 plus 10.0).

The hysteresis units are expressed in displayed engineering units.

RxTt (alarm trip time)

Displays and sets the alarm trip time and is common for both alarm high and low setpoint values. The trip time is the delay time before the alarm relay will trip when an alarm condition is present. The alarm condition must be present continuously for the trip time period before the alarm will trip. This function is useful for preventing an alarm trip due to short non critical deviations from setpoint. The trip time is selectable over **0** to **9999** seconds.

RxRt (alarm reset time)

Displays and sets the alarm relay reset time. With the alarm condition is removed the alarm relay will stay in its alarm condition for the time selected as the reset time. The reset time is selectable over **0** to **9999** seconds.

RxNo or RxNc (alarm x normally open or normally closed)

Displays and sets the alarm relay action to normally open (de-energised) or normally closed (energised), when no alarm condition is present. A normally closed alarm is often used to provide a power failure alarm indication.

RxSP, RxT1, RxT2 etc. (relay operation independent setpoint or trailing)

Each alarm may be programmed to operate with an independent setpoint setting or may be linked (or trailing) to operate at a fixed difference to another relay setpoint. The operation is as follows: Alarm 1 (**R1**) is always independent. Alarm 2 (**R2**) may be independent or may be linked to Alarm 1. Alarm 3 (**R3**) may be independent or may be linked to Alarm 1 or Alarm 2. Alarm 4 (**R4**) may be

independent or may be linked to Alarm 1, Alarm 2 or Alarm 3. The operation of each alarm is selectable within the Function Setup Mode by selecting, for example, (Alarm 4) **A4.SP** = Alarm 4 normal setpoint or **A4.T 1** = Alarm 4 trailing Alarm 1 or **A4.T 2** = Alarm 4 trailing Alarm 2 or **A4.T 3** = Alarm 4 trailing Alarm 3. For trailing set points the setpoint value is entered as the difference from the setpoint being trailed. If the trailing setpoint is to operate ahead of the prime setpoint then the value is entered as a positive number and if operating behind the prime setpoint then the value is entered as a negative number. For example, with Alarm 2 set to trail alarm 1, if **A1H** is set to 1000 and **A2H** is set to 50 then Alarm 1 will trip at 1000 and alarm 2 will trip at 1050 (i.e. 1000 + 50). If Alarm 2 had been set at -50 then alarm 2 would trip at 950 (i.e. 1000 - 50).

See the trailing alarm table which follows.

Trailing Alarm Table Showing Possible Alarm Assignments			
	A2	A3	A4
A1	A2.T 1	A3.T 1	A4.T 1
A2		A3.T 2	A4.T 2
A3			A4.T 3

br 9t (display brightness)

Displays and sets the digital display brightness. The display brightness is selectable from **0** to **15**, where **0** = lowest intensity and **15** = highest intensity. This function is useful for reducing glare in low light environments.

dULL (remote display brightness)

Displays and sets the level for remote input brightness switching, see **r.i NP** function. When the remote input is set to **dULL** the remote input can be used to switch between the display brightness level set by the **br 9t** function and the display brightness set by the **dULL** function. The display brightness is selectable from **0** to **15**, where **0** = lowest intensity and **15** = highest intensity. This function is useful in reducing glare when the display needs to be viewed in both light and dark ambient light levels.

d.OFF SECS (Auto display dimming timer)

This function allows a time to be set after which the display brightness (set by the **br 9t** function) will automatically be set to the level set at the **dULL** function. The auto dimming feature can be used to reduce power consumption. The function can be set to any value between **0** and **9999** seconds. A setting of **0** disables the auto dimming. The display brightness can be restored by pressing any of the instruments front push buttons. The display brightness will also be restored whilst one or more alarm relays is activated.

r EC - (recorder/retransmission output low value) - only seen with analog output option. Refer to the separate "RM4 Panel Meter Optional Output Addendum" booklet supplied when this option is fitted.

Displays and sets the analog retransmission (4-20mA, 0-1V or 0-10V, link selectable) output low value (4mA or 0V) in displayed engineering units. e.g. if it is required to retransmit 4mA when the display indicates **0** then select **0** in this function via the **▲** or **▼** button.

r EC ~ (recorder/retransmission output high value) - only seen with analog output option. Refer to the separate "RM4 Panel Meter Optional Output Addendum" booklet supplied when this option is fitted.

Displays and sets the analog retransmission (4-20mA, 0-1V or 0-10V, link selectable) output high value (20mA, 1V or 10V) in displayed engineering units. e.g. if it is required to retransmit 20mA when the display indicates **500** then select **500** in this function via the **▲** or **▼** button.

dr nd (display rounding)

Displays and sets the display rounding value. This value may be set from **1-5000** displayed units (e.g. **0.00 1** to **5.000** if decimal point set to 3 places). Display rounding is useful for reducing the instrument resolution without loss of accuracy in applications where it is undesirable to display to a fine tolerance. (example: if set to **10** the instruments display will increment in multiples of 10).

7.1 RP (remote input function)

Terminals 5 and 6 are the remote input terminals. When these terminals are short circuited, via a pushbutton or keyswitch the instrument will perform the selected remote input function. A message will flash to indicate which function has been selected when the remote input pins are short circuited. The remote input functions are as follows:

NONE - no remote function required

P.Hld - peak hold. The display will show the peak hold value whilst the remote input terminals are short circuited

d.Hld - display hold. The display will hold its value whilst the remote input terminals are short circuited.

H_i - peak memory. The peak value stored in memory will be displayed if the remote input terminals are short circuited, if the short circuit is momentary then the display will return to normal measurement after 20 seconds. If the short circuit is held for 1 to 2 seconds then the memory will be cleared.

L_o - valley memory. The minimum value stored in memory will be displayed. Otherwise operates in the same manner as the **H_i** function. If the short circuit is held for 1 to 2 seconds then the memory will be cleared.

H_i L_o - toggle between **H_i** and **L_o** displays. This function allows the remote input to be used to toggle between peak and valley memory displays. The first operation of the remote input will cause the peak memory value to be displayed, the next operation will give a valley memory display. **PH_i** or **PL_o** will flash before each display to give an indication of display type. . If the short circuit is held for 1 to 2 seconds then the memory will be cleared.

ZEFO - zero the display. The total will be zeroed when the remote input is short circuited.

SP.AC - setpoint access only. This blocks access to any functions except the alarm setpoint functions unless the remote input pins are short circuited or entry is made via **CAL** mode.

No.AC - no access. This blocks access to all functions unless the remote input pins are short circuited or entry is made via **CAL** mode.

d: SP - display toggle. Not applicable to this manual.

dULL - display brightness control. The remote input can be used to change the display brightness. When this mode is selected the display brightness can be switched, via the remote input, between the brightness level set at the **brSt** function and the brightness level set at the **dULL** function.

g.rSt - grand total reset. Not applicable to this manual.

P.but (P button function)

The **P** button may be set to operate some of the remote input functions. With some functions, to prevent accidental operation, the **P** button must be held pressed for 2-3 seconds before the function will operate. If both the remote input and **P** button function are operated simultaneously the **P** button will override the remote input.

The functions below are as described in the **7.1 RP** function above with the exception of the **FUNC** function.

Functions available are:

NONE, H_i, L_o, H_i L_o, ZEFO, d: SP, FUNC and g.rSt

The **FUNC** function allows the preset value used with the down timer (when in **PEFd** mode) to be displayed and set without the need to enter **CAL** and **FUNC** modes. Note that this is an alternative method to setting the preset value at the **P.SET** function. To alter the **FUNC** (preset) value press the **P** pushbutton, the display will indicate **FUNC** followed by the current preset value. This value may now be altered via the **▲** or **▼** pushbutton. When the preset value is set as required press, then release, the **F** pushbutton, the display will indicate **End** and will return to normal measurement.

ACCESS (access mode)

The access mode function **ACCESS** has four possible settings namely **OFF, EASY, NONE** and **ALL**. If set to off the mode function has no effect or alarm relay operation. If set to **EASY** the "easy alarm access" mode will be activated, see page 16 for a description. If set to **NONE** there will be no access to any functions via **FUNC** mode, entry via **CAL** mode must be made to gain access to alarm functions. If set to **ALL** then access to all functions can be made via **FUNC** mode i.e. there is no need to enter **CAL** mode.

SPAC (setpoint access) - only seen if more than 1 relay fitted

Sets the access to the alarm relay set points. The following choices are available: **R 1** - Allows setpoint access to alarm 1 only. **R 1-2** - Allows access to alarms 1 and 2 only. **R 1-3** allows access to alarms 1,2 and 3 etc. up to the maximum number of relays fitted. For this function to operate the remote input function must be set to **SP.AC**.

dCPE (decimal point selection)

Displays and sets the decimal point for the scaled period or period display. By pressing the or pushbuttons the decimal point position may be set. The display will indicate as follows: **0** (no decimal point), **0. 1** (1 decimal place) or **0.02** (2 decimal places). Two decimal places is the limit for period measurement mode.

Note: the displayed value is also affected by the decimal point and display range settings. The table below shows some possible **d: SP RANGE** and **dCPE** settings and their effect on the measured value.

d: SP RANGE	dCPE	Measured values
SECS	0	Seconds
	0. 1	Seconds & tenths of seconds
	0.02	Seconds & hundredths of seconds
m̄m̄.SS	0.00	Minutes & seconds
	0.00. 1	Minutes, seconds & tenths of seconds
	0.02	Seconds & hundredths of seconds
h̄m̄.S	0.00	Minutes & seconds
	0.00. 1	Minutes, seconds & tenths of seconds
	0.02	Seconds & hundredths of seconds
m̄m̄m̄	0	Minutes
	0. 1	Minutes & tenths of minutes
	0.02	Minutes & hundredths of minutes
hh̄m̄m̄	0.00	Hours & minutes
	0.00. 1	Hours, minutes & tenths of minutes
	0.02	Minutes & hundredths of minutes
hr̄S	0	Hours
	0. 1	Hours & tenths of hours
	0.02	Hours & hundredths of hours
dd̄.hh̄	0.00	Days & hours
	0.00. 1	Days, hours & tenths of hours
	0.02	Hours & hundredths of hours
dRYS	0	Days
	0. 1	Days & tenths of days
	0.02	Days & hundredths of days

OPEF (period operating mode)

Displays and sets the operation mode to be used in measuring the pulse period. The active state is set by the **I NPE** function as either a high or low signal. The options are as follows:

Mode	Operation
run (run)	The run option allows accumulated time display. The mode operates in the following manner: Input inactive: The timer stops but holds the time display. Input active: The timer continues timing from the previous time i.e. the time accumulates.
dur (duration)	The duration option allows display of an input time with a reset at the end of the input. The mode operates in the following manner: Input inactive: The timer is automatically reset and the display shows zero or the preset value. Input active: The timer starts timing from zero or the preset value.
PLSE (pulse)	The pulse option allows timing of the duration of an input pulse. The mode operates in the following manner: Input inactive: The display will hold the time of the last pulse. Input active: The display resets to zero (preset does not apply to this mode) then starts timing the new pulse.
Sngl (single pulse)	The single pulse option allows timing of the duration of a pulse. The mode operates in the following manner: Input inactive: The display will hold the time of the last pulse. The display must be reset before a new pulse can be timed. Input active: If the previous time display has been reset then the timing process will start from zero or the preset value. If the previous display has not been reset the value displayed will not change when the input becomes active.
PLS.H (pulse held)	The pulse held option operates in the same manner as the PLSE option with the exception that the display indication only changes at the end of the active input i.e. the previous display is held until the new active input ends. Preset does not apply to this mode.
Sng.H (single pulse held)	The pulse held option operates in the same manner as the Sngl option with the exception that the display indication only changes at the end of the input pulse. As with the Sngl option the display must be reset before a new pulse can be timed.
UP (up timer)	The up timer option allows the instrument to be used as a timer with a start, stop and reset input (see INPE and SI NP functions for edge settings for these inputs). Note the CRSE function must be set to ZERO if this mode is used. The mode operates in the following manner: Upon receiving an active input the display will show accumulated time. This timing will continue until a STOP input is received even if the input becomes inactive. This STOP input is operated via an edge between the GND and SET terminals. A reset input will reset the timer to zero. If the timer is stopped and then restarted without a reset the timing will continue from the previous time.
dn (down timer)	The down timer works in the same manner as the UP timer with the exception that the down timing will automatically start from the number set at the PSET function. The CRSE function must be set to PSET if this mode is used.
R.dur (accumulating duration)	The accumulating duration mode allows displays of current timing period and accumulated total. The mode operates in the following manner: Input active: Display starts timing from zero (preset does not apply to this mode). Input inactive: Display shows accumulated time from previous timing periods. A reset operation must be carried out when the accumulated total needs to be reset.

di SP RANGE (display range) - only seen in **PER-d** mode.

The display range function allows selection of various display modes. Eight different modes are available these are:

SECS for a display in seconds

m.m.ss for a display in minutes and seconds.

h.m.s for a display in hours, minutes and seconds.

m.m.m for a display in minutes.

h.h.m.m for a display in hours and minutes

- h r S** for a display in hours
- dd.hh** for a display in days and hours
- dAYS** for a display in days

The display is also affected by the decimal point setting. Examples below show how a 100 second input is affected by the **di SP rNGE** and **dCPE** functions. Examples are shown for a 4 digit display type instrument.

dCPE	di SP rNGE	DISPLAY
0	SECS	100 i.e. 100 seconds with a no decimal points display
0.1	SECS	100.0 i.e. 100.0 seconds
0.02	mm.ss	1.40 i.e. 1 minute and 40 seconds (100.00 seconds)

P.SET (preset value)

This function displays and sets the preset value to be used when the **OPER** function is set to down count timer (**dn**). Note that the **P** button may be programmed to allow access to the preset value also. The preset value is the value which will automatically be set when a timing process starts in down count mode. See also **crSE** function which sets the reset mode.

SPAC (setpoint access)

Sets the access to the alarm relay set points. The following choices are available: **R 1** - Allows setpoint access to alarm 1 only. **R 1-2** - Allows access to alarms 1 and 2 only. **R 1-3** allows access to alarms 1,2 and 3 etc. up to the maximum number of relays fitted. For this function to operate the remote input function must be set to **SP.AC**.

i rPE (input type)

Displays and sets the input type to be used for period measurement. If set to **Lo** then the instrument will measure the period of an input with a low going edge. If set to **hi Sh** then the instrument will measure the period of an input with a high going edge.

S.i rP (SET terminal input)

Displays and sets the input type to be used to halt the timing process when using the up or down count timer. The SET input (terminal 10) is used as the stop input when using the up or down timer, ensure that LK4 is in and that LK1, 2 & 3 are out (see page 5 for further details). If set to **Lo** then the timing will be held when a low going edge is received, if set to **hi Sh** then the timing will be held when a high going edge is received.

crSE (reset value)

The reset terminal can be programmed to cause the display to reset to either zero or the selected preset value. Choose either **ZER0** or **P.SET** to select the required operation.

crSE (reset mode)

Allows selection of reset level or edge to force a reset. If set to **Lo** a low input level or closed switch on the reset line will force a reset. If set to **Hi** a high input level or open switch on the reset line will force a reset. If set to **LoE** then a falling edge or switch closure on the reset line will force a reset. If set to **Hi E** then a rising edge or switch opening on the reset line will force a reset.

dbnc (debounce)

Displays and sets the debounce time. The debounce time can be set from 0 to 1000 displayed units. If the input pulse width is less than the debounce time setting then the input will be ignored and will not be displayed.

SEt OPER (set operating mode)

Displays and sets the selected operating mode, e.g. select **S.Pr-d** for scaled period measurement. See the dedicated chapter in this manual for description of the required operating mode. Options are:

- S.Pr-d** - Scaled period measurement
- r.t.c** - Not applicable to this manual
- PER-d** - Period measurement
- both** - Not applicable to this manual
- t.o.t.L** - Not applicable to this manual
- F.F.E.9** - Not applicable to this manual

Serial communication functions

The following serial communications functions apply only if the serial communications option is fitted. Refer to the separate “RM4 Panel Meter Optional Output Addendum” booklet supplied when this option is fitted.

BRud (set baud rate). Refer to the separate “RM4 Panel Meter Optional Output Addendum” booklet supplied when this option is fitted.

Select from **300 . 600 . 1200 . 2400 . 4800 . 9600 . 19.2** or **38.4**.

PrEtY (set parity). Refer to the separate “RM4 Panel Meter Optional Output Addendum” booklet supplied when this option is fitted.

Select parity check to either **NONE**, **EVEN** or **odd**.

Q.PuE (set RS232/485 interface mode). Refer to the separate “RM4 Panel Meter Optional Output Addendum” booklet supplied when this option is fitted.

Select **d**, **SP**, **Cont**, **POLL** or **n.bus**

Allows user to select the RS232/485 interface operation as follows:-

d, **SP** Sends image data from the display without conversion to ASCII.

Cont Sends ASCII form of display data every time display is updated.

POLL Controlled by computer or PLC as host. Host sends command via RS232/485 and instrument responds as required.

n.bus Modbus RTU protocol.

Addr (set unit address for polled (POLL) mode (0 to 31)). Refer to the separate “RM4 Panel Meter Optional Output Addendum” booklet supplied when this option is fitted.

Allows several units to operate on the same RS485 interface reporting on different areas etc. The host computer or PLC may poll each unit in turn supplying the appropriate address. The unit address ranges from 0 to 31 (DEC) but is offset by 32 (DEC) to avoid clashing with ASCII special function characters (such as <STX> and <CR>). Therefore 32 (DEC) or 20 (HEX) is address 0, 42 (DEC) or 2A (HEX) addresses unit 10.

Returning to the normal measure mode

When the calibration procedure has been completed it is advisable to return the instrument to the normal mode (where calibration functions cannot be tampered with). To return to the normal mode, turn off power to the instrument, wait a few seconds and then restore power.

4.2 Period measurement examples

Example 1 - Stopwatch operation

To operate as an up counting stopwatch (start/stop and reset inputs) and display in hours, minutes and seconds choose **hNS** mode at the **d: SP FN9E** function. Choose **UP** at the **OPER** function. The **c.rSt** function must be set to **2EFG**.

To operate as a down counting stopwatch (start/stop and reset inputs) and display in hours, minutes and seconds choose **hNS** mode at the **d: SP FN9E** function. Choose **dn** at the **OPER** function. The **c.rSt** function must be set to **P.5Et**.

Example 2 - Elapsed time operation

To operate as a simple elapsed time display with a start and reset input and a display in seconds choose **SECS** mode at the **di SP RANGE** function. Choose **SINGL** at the **OPEF** function. The **CRSE** function must be set to **ZERO**. Whilst the input is active the display will increment in seconds. When the input becomes inactive the time display will be held. To start from zero a reset input must be given.

Example 3 - Pulse timer operation

To operate as a simple pulse timer display with a display in minutes and seconds choose **mm.ss** mode at the **di SP RANGE** function. Choose **PULSE** at the **OPEF** function. When the input becomes active the display will automatically reset to zero and start timing from zero. When the input becomes inactive the display will hold the time of the last pulse.

4.3 Function table - period mode

Initial display	Meaning of display	Next display	Default Setting	Record Your Settings
<i>RxLo</i>	Alarm low setpoint value	Setpoint value or <i>OFF</i>	<i>OFF</i>	
<i>RxHi</i>	Alarm high setpoint value	Setpoint value or <i>OFF</i>	<i>OFF</i>	
<i>RxHy</i>	Alarm hysteresis	0 to <i>5000</i>	<i>10</i>	
<i>Rxtt</i>	Alarm trip time	0 to <i>9999</i>	<i>0</i>	
<i>Rxrt</i>	Alarm reset time	0 to <i>9999</i>	<i>0</i>	
<i>Rxn.o</i> or <i>Rxn.c</i>	Alarm action N/O or N/C	<i>Rxn.o</i> or <i>Rxn.c</i>	<i>Rxn.o</i>	
<i>RxSP</i> or <i>Rxt!</i> etc	Setpoint or trailing alarm	<i>RxSP</i> or <i>Rxt!</i> etc	<i>RxSP</i>	
<i>brgt</i>	Digital display brightness	0 to <i>15</i> (<i>15</i> = highest brightness)	<i>15</i>	
<i>dULL</i>	Remote input brightness control	0 to <i>15</i> (<i>15</i> = highest brightness)	<i>0</i>	
<i>FEC-</i>	Analog retransmission low value	Value in memory	<i>0</i>	
<i>FEC+</i>	Analog retransmission high value	Value in memory	<i>1000</i>	
<i>P.SET</i>	Preset value	Value in memory	<i>0</i>	
The functions below are accessible only via <i>CAL</i> mode or if the <i>ACCESS</i> function is set to <i>ALL</i>				
<i>d.OFF SECS</i>	Display auto dimming timer (seconds)	0 to <i>9999</i>	<i>0</i>	
<i>drnd</i>	Display rounding selects resolution	Value in memory	<i>1</i>	
<i>r.i NP</i>	Remote input	<i>NONE</i> , <i>PHLd</i> , <i>d.HLd</i> , <i>H</i> , <i>Lo</i> , <i>H</i> , <i>Lo</i> , <i>2EFD</i> , <i>SP</i> , <i>Ac</i> , <i>No</i> , <i>Ac</i> , <i>di</i> , <i>SP</i> , <i>dULL</i> or <i>g.rSt</i>	<i>NONE</i>	
<i>P.but</i>	 Button operation	<i>NONE</i> , <i>H</i> , <i>Lo</i> , <i>H</i> , <i>Lo</i> , <i>2EFD</i> , <i>di</i> , <i>SP</i> , <i>FUNC</i> or <i>g.rSt</i>	<i>NONE</i>	
<i>ACCESS</i>	Access mode	<i>OFF</i> , <i>EASY</i> , <i>NONE</i> or <i>ALL</i>	<i>OFF</i>	
<i>SPAC</i>	Setpoint access	<i>R1</i> , <i>R1-2</i> etc	<i>R1</i>	
<i>dCPE</i>	Decimal point setting	0, 0.1 or 0.02	<i>0</i>	
<i>OPER</i>	Operation mode	<i>run</i> , <i>dur</i> , <i>PLSE</i> , <i>Sn9L</i> , <i>PLS</i> , <i>H</i> , <i>Sn9</i> , <i>H</i> , <i>UP</i> , <i>dn</i> or <i>R</i> , <i>dur</i>	<i>dur</i>	
<i>di SP RANGE</i>	Display range	<i>dAYS</i> , <i>dd</i> , <i>hh</i> , <i>hr</i> , <i>S</i> , <i>hh</i> , <i>nn</i> , <i>nn</i> , <i>hh</i> , <i>S</i> , <i>nn</i> , <i>SS</i> or <i>SECS</i>	<i>SECS</i>	
<i>i NPt</i>	Input level type	<i>Lo</i> or <i>hi</i> , <i>gh</i>	<i>Lo</i>	
<i>s.i NP</i>	Stop input edge type	<i>Lo</i> or <i>hi</i> , <i>gh</i>	<i>Lo</i>	
<i>c.rSt</i>	Counter reset value	<i>2EFD</i> or <i>P.SET</i>	<i>2EFD</i>	
<i>c.rSt</i>	Counter reset mode	<i>Lo</i> , <i>H</i> , <i>LoE</i> or <i>H</i> , <i>E</i>	<i>Lo</i>	
<i>dbnc</i>	Debounce time (mS)	0 to <i>9999</i>	<i>0</i>	
<i>SEt OPER</i>	Set operating mode	<i>S</i> , <i>Prd</i> , <i>rtc</i> , <i>PEFd</i> , <i>both</i> , <i>totL</i> or <i>FREQ</i>	<i>PEFd</i>	
<i>brUd RATE</i>	Baud rate.	<i>300</i> , <i>600</i> , <i>1200</i> , <i>2400</i> , <i>4800</i> , <i>9600</i> , <i>19.2</i> or <i>38.4</i>	<i>9600</i>	
<i>Prty</i>	Parity select.	<i>NONE</i> , <i>EVEN</i> or <i>Odd</i>	<i>NONE</i>	
<i>O.Put</i>	Output, continuous or controlled.	<i>POLL</i> , <i>Cont</i> or <i>di SP</i>	<i>POLL</i>	
<i>Addr</i>	Set unit address for <i>POLL</i> mode.	0 to <i>31</i>	<i>0</i>	

Functions shaded only be seen if those options are fitted.

5 Scaled period measurement

This chapter refers to the “scaled period measurement” (*S.Prd*) mode operation. The scaled period mode allows an event to be timed and scaled to match the display units required rather than showing the true time. This mode may be selected via the **SEt OPEr** function. The scaled period mode has four different operating modes, namely **PLSE** (pulse), **SngL** (single pulse), **PLS.F** (pulse reciprocal) and **Sng.F** (single pulse reciprocal). The pulse reciprocal and single pulse reciprocal allow the display to be scaled with the result being inversely proportional to time, this allows scaling in units such as velocity e.g. cm/sec, km/hr etc.

Scaled period measurement

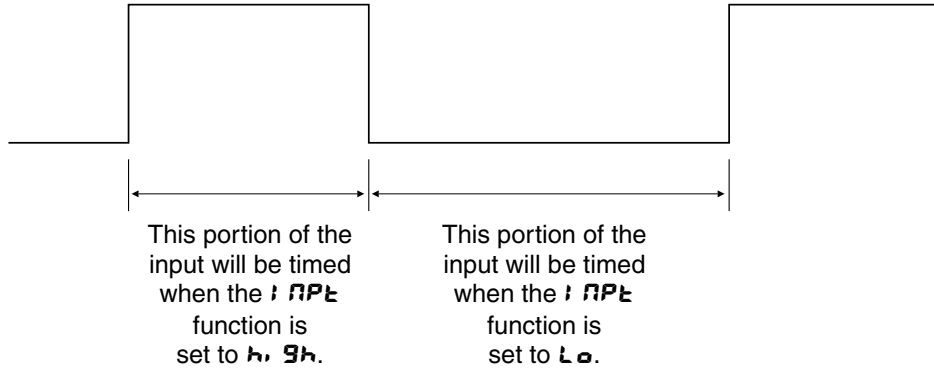

Note: this model will time the low **or** the high period of the waveform, not the overall period. The measured period can be scaled and/or the reciprocal taken before being displayed.

Remember that you will need to enter via **CAL** or **FUNE** mode (see section 1.1) to gain access to functions, the function table for each mode shows which functions require entry via **CAL** mode.

Note: a number relays are available with certain option combinations (a maximum of 4 relays may be fitted to the RM4-TMR if no other options such as retransmission are required), the alarm functions are displayed only for the actual number of relays provided. The “x” shown in the following display messages represents the alarm number i.e. **RxLo** as shown in the text will appear as **R1 Lo**, **R2Lo** etc. on the instrument display.

The RM4-TMR has an easy alarm access facility which allows access to the alarm setpoints simply by pressing the **F** button at the front or rear of the instrument. The first setpoint will then appear and changes to this setpoint may be made to this setpoint via the **▲** or **▼** buttons. Press the **F** button to accept any changes or to move on to the next setpoint.

The instrument must be set in the manner described below in order for the easy access to work:

1. The **I NPt** function must be set to **SP.AC**.
2. At least one alarm must have a setpoint, nothing will happen if all the alarm setpoints are set to **OFF**.
3. The **SP.AC** function must be set to allow access to the relays required e.g. if set to **R 1-2** then the easy access will work only with alarm relays 1 and 2 even if more relays are fitted.
4. The instrument must be in normal measure mode i.e. if the instrument is powered up so that it is in **CAL** mode then the easy access will not function. If in doubt then remove power from the instrument, wait for a few seconds then apply power again.
5. If the easy access facility is used then the only way to view or alter any other function settings is to power up via **CAL** mode i.e. there is not entry to **FUNE** mode unless the instrument is powered up in **CAL** mode.



5.1 Explanation of functions

RxLo (alarm low setpoint)

Displays and sets the alarm low setpoint value for the designated alarm relay. The low alarm setpoint may be disabled by pressing the **▲** and **▼** pushbuttons simultaneously. When the alarm is disabled the display will indicate **OFF**. The alarm relay will trip when the displayed value is less than the **RxLo** setpoint value. Relays may be configured with both a low and high setpoint, so the relay may be tripped when the reading moves outside the band set between low and high. e.g. if **R 1Lo** is set to **10.0** and **R 1H** is set to **90.0** then the alarm output relay will trip when the display value either goes below

10.0 or goes above 90.0.

RxH (alarm high setpoint)

Displays and sets the alarm high setpoint value for the designated alarm relay. The high alarm setpoint may be disabled by pressing the  and  pushbuttons simultaneously. When the alarm is disabled the display will indicate OFF. The alarm relay will trip when the displayed value is greater than the RxH setpoint value. Relays may be configured with both a low and high setpoint, so the relay may be tripped when the reading moves outside the band set between low and high (see RxLo for example).

RxHY (alarm hysteresis [deadband])

Displays and sets the alarm hysteresis limit and is common for both high and low setpoint values. The hysteresis value may be used to prevent too frequent operation of the alarm relay when the measured value stays close to the setpoint. Without a hysteresis setting (RxHY set to zero) the alarm will trip when the display value goes above the alarm setpoint (for high alarm) and will reset when the display value falls below the setpoint, this can result in repeated on/off switching of the relay at around the setpoint value. The hysteresis setting operates as follows:

In the high alarm mode, once the alarm is tripped the input must fall below the setpoint value minus the hysteresis value to reset the alarm.

e.g. if RxH is set to 50.0 and RxHY is set to 3.0 then the alarm output relay will trip once the display value goes above 50.0 and will reset when the display value goes below 47.0 (50.0 minus 3.0).

In the low alarm mode, once the alarm is tripped the input must rise above the setpoint value plus the hysteresis value to reset the alarm.

e.g. if RxLo is set to 20.0 and RxHY is set to 10.0 then the alarm output relay will trip when the display value falls below 20.0 and will reset when the display value goes above 30.0 (20.0 plus 10.0).

The hysteresis units are expressed in displayed engineering units.

RxT (alarm trip time)

Displays and sets the alarm trip time and is common for both alarm high and low setpoint values. The trip time is the delay time before the alarm relay will trip when an alarm condition is present. The alarm condition must be present continuously for the trip time period before the alarm will trip. This function is useful for preventing an alarm trip due to short non critical deviations from setpoint. The trip time is selectable over 0 to 9999 seconds.

RxR (alarm reset time)

Displays and sets the alarm relay reset time. With the alarm condition is removed the alarm relay will stay in its alarm condition for the time selected as the reset time. The reset time is selectable over 0 to 9999 seconds.

Rxno or Rxnc (alarm x normally open or normally closed)

Displays and sets the alarm relay action to normally open (de-energised) or normally closed (energised), when no alarm condition is present. A normally closed alarm is often used to provide a power failure alarm indication.

RxSP, RxT1, RxT2 etc. (relay operation independent setpoint or trailing)

Each alarm may be programmed to operate with an independent setpoint setting or may be linked (or trailing) to operate at a fixed difference to another relay setpoint. The operation is as follows: Alarm 1 (R1) is always independent. Alarm 2 (R2) may be independent or may be linked to Alarm 1. Alarm 3 (R3) may be independent or may be linked to Alarm 1 or Alarm 2. Alarm 4 (R4) may be independent or may be linked to Alarm 1, Alarm 2 or Alarm 3. The operation of each alarm is selectable within the Function Setup Mode by selecting, for example, (Alarm 4) Rx4.SP = Alarm 4 normal setpoint or Rx4.T1 = Alarm 4 trailing Alarm 1 or Rx4.T2 = Alarm 4 trailing Alarm 2 or Rx4.T3 = Alarm 4 trailing Alarm 3. For trailing set points the setpoint value is entered as the difference from the setpoint being trailed. If the trailing setpoint is to operate ahead of the prime setpoint then the value is entered as a positive number and if operating behind the prime setpoint then the value is entered as a negative number. For example, with Alarm 2 set to trail alarm 1, if RxH1 is set to 1000 and RxH2 is set to 50 then Alarm 1 will trip at 1000 and alarm 2 will trip at 1050 (i.e. 1000 + 50). If Alarm 2 had been set at -50 then alarm 2 would trip at 950 (i.e. 1000 - 50).

See the trailing alarm table which follows.

Trailing Alarm Table Showing Possible Alarm Assignments			
	A2	A3	A4
A1	A2.E1	A3.E1	A4.E1
A2		A3.E2	A4.E2
A3			A4.E3

b.r.g.t (display brightness)

Displays and sets the digital display brightness. The display brightness is selectable from **0** to **15**, where **0** = lowest intensity and **15** = highest intensity. This function is useful for reducing glare in low light environments.

d.u.l.l (remote display brightness)

Displays and sets the level for remote input brightness switching, see **r.i.n.p** function. When the remote input is set to **d.u.l.l** the remote input can be used to switch between the display brightness level set by the **b.r.g.t** function and the display brightness set by the **d.u.l.l** function. The display brightness is selectable from **0** to **15**, where **0** = lowest intensity and **15** = highest intensity. This function is useful in reducing glare when the display needs to be viewed in both light and dark ambient light levels.

r.e.c.l (recorder/retransmission output low value) - only seen with analog output option. Refer to the separate "RM4 Panel Meter Optional Output Addendum" booklet supplied when this option is fitted.

Displays and sets the analog retransmission (4-20mA, 0-1V or 0-10V, link selectable) output low value (4mA or 0V) in displayed engineering units. e.g. if it is required to retransmit 4mA when the display indicates **0** then select **0** in this function via the **▲** or **▼** button.

r.e.c.h (recorder/retransmission output high value) - only seen with analog output option. Refer to the separate "RM4 Panel Meter Optional Output Addendum" booklet supplied when this option is fitted.

Displays and sets the analog retransmission (4-20mA, 0-1V or 0-10V, link selectable) output high value (20mA, 1V or 10V) in displayed engineering units. e.g. if it is required to retransmit 20mA when the display indicates **500** then select **500** in this function via the **▲** or **▼** button.

d.o.f.f.s.e.c.s (Auto display dimming timer)

This function allows a time to be set after which the display brightness (set by the **b.r.g.t** function) will automatically be set to the level set at the **d.u.l.l** function. The auto dimming feature can be used to reduce power consumption. The function can be set to any value between **0** and **9999** seconds. A setting of **0** disables the auto dimming. The display brightness can be restored by pressing any of the instruments front push buttons. The display brightness will also be restored whilst one or more alarm relays is activated.

d.r.o.d (display rounding)

Displays and sets the display rounding value. This value may be set from **1-5000** displayed units (e.g. **0.001** to **5.000** if decimal point set to 3 places). Display rounding is useful for reducing the instrument resolution without loss of accuracy in applications where it is undesirable to display to a fine tolerance. (example: if set to **10** the instruments display will increment in multiples of 10).

r.i.n.p (remote input function)

Terminals 5 and 6 are the remote input terminals. When these terminals are short circuited, via a pushbutton or keyswitch the instrument will perform the selected remote input function. A message will flash to indicate which function has been selected when the remote input pins are short circuited. The remote input functions are as follows:

n.o.n.e - no remote function required

p.h.l.d - peak hold. The display will show the peak hold value whilst the remote input terminals are short circuited

d.h.l.d - display hold. The display will hold its value whilst the remote input terminals are short circuited

H - peak memory. The peak value stored in memory will be displayed if the remote input terminals are short circuited, if the short circuit is momentary then the display will return to normal measurement after 20 seconds. If the short circuit is held for 1 to 2 seconds then the memory will be cleared.

L_o - valley memory. The minimum value stored in memory will be displayed. Otherwise operates in the same manner as the **H** function. If the short circuit is held for 1 to 2 seconds then the memory will be cleared.

H, L_o - toggle between **H** and **L_o** displays. This function allows the remote input to be used to toggle between peak and valley memory displays. The first operation of the remote input will cause the peak memory value to be displayed, the next operation will give a valley memory display. **PH** or **PL_o** will flash before each display to give an indication of display type. . If the short circuit is held for 1 to 2 seconds then the memory will be cleared.

ZERO - zero the display. The total will be zeroed when the remote input is short circuited.

SP.AC - setpoint access only. This blocks access to any functions except the alarm setpoint functions unless the remote input pins are short circuited or entry is made via **CAL** mode.

No.AC - no access. This blocks access to all functions unless the remote input pins are short circuited or entry is made via **CAL** mode.

d: SP - display toggle. Not applicable to this manual.

dULL - display brightness control. The remote input can be used to change the display brightness. When this mode is selected the display brightness can be switched, via the remote input, between the brightness level set at the **br 9t** function and the brightness level set at the **dULL** function.

9.r 5t - grand total reset. Not applicable to this manual.

P.but (P button function)

The **P** button may be set to operate some of the remote input functions. With some functions, to prevent accidental operation, the **P** button must be held pressed for 2-3 seconds before the function will operate. If both the remote input and **P** button function are operated simultaneously the **P** button will override the remote input.

The functions below are as described in the **F: NP** function above with the exception of the **FUNC** function.

Functions available are:

NONE, H, L_o, H, L_o, ZERO, d: SP, FUNC and **9.r 5t**

The **FUNC** function allows the preset value used with the down timer (when in **PER d** mode) to be displayed and set without the need to enter **CAL** and **FUNC** modes. Note that this is an alternative method to setting the preset value at the **P.SET** function. To alter the **FUNC** (preset) value press the **P** pushbutton, the display will indicate **FUNC** followed by the current preset value. This value may now be altered via the **▲** or **▼** pushbutton. When the preset value is set as required press, then release, the **F** pushbutton, the display will indicate **End** and will return to normal measurement.

ACCESS (access mode)

The access mode function **ACCESS** has four possible settings namely **OFF, EASY, NONE** and **ALL**. If set to off the mode function has no effect or alarm relay operation. If set to **EASY** the "easy alarm access" mode will be activated, see page 16 for a description. If set to **NONE** there will be no access to any functions via **FUNC** mode, entry via **CAL** mode must be made to gain access to alarm functions. If set to **ALL** then access to all functions can be made via **FUNC** mode i.e. there is no need to enter **CAL** mode.

SPAC (setpoint access) - only seen if more than 1 relay fitted.

Sets the access to the alarm relay set points. The following choices are available: **A 1** - Allows setpoint access to alarm 1 only. **A 1-2** - Allows access to alarms 1 and 2 only. **A 1-3** allows access to alarms 1,2 and 3 etc. up to the maximum number of relays fitted. For this function to operate the remote input function (**F: NP**) must be set to **SP.AC**.

dCPt (decimal point selection)

Displays and sets the decimal point for the scaled period or period display. By pressing the **▲** or **▼** pushbuttons the decimal point position may be set. The display will indicate as follows: **0** (no decimal point), **0. 1** (1 decimal place), **0.02** (2 decimal places), **0.003** (3 decimal places) or 0.0004 (4

decimal places).

QPEF (scaled period operating mode)

Displays and sets the operation mode to be used in measuring the pulse period. The options are as follows:

PLSE (pulse) - When this mode is selected the period of the input pulse is displayed according to the scaling factors (**PERD:INPT** and **PERD:SCALE**). When a new pulse is applied to the input the instrument will measure, scale and display the new period i.e. the old display will be overwritten.

SNGL (single pulse) - This mode will display the period (again see **PERD:INPT** and **PERD:SCALE**) of the first pulse and will hold this display value until reset via a contact closure across the reset lines i.e. the display will not be overwritten by any subsequent input pulses.

PLS.F (pulse reciprocal) - Functions in the same manner as the **PLSE** mode except that the display will show the inverse of the period. This is useful for displaying rate, velocity and other measuring units requiring a time reciprocal.

SNG.F (single pulse reciprocal) - Functions in the same manner as the **SNGL** mode except that the display will show the inverse of the period. This is useful for displaying rate, velocity and other measuring units requiring a time reciprocal.

PERD:INPT (period input scale factor) - S.Prd mode only.

Displays and sets the period input scale factor to be used with the period scale function to generate the display scaling. In **S.Prd** mode the period input is measured in seconds.

PERD:SCALE (period scale factor)

Displays and sets the scale factor to be used with the period input setting (see chapter 7 "Period Operation" for examples). To calculate the display value the input frequency and hence the period of this input needs to be known. Scale and input work together to produce a display as follows:

$$\text{Display Value} = \frac{\text{input period (seconds)} \times \text{PERD:SCALE}}{\text{PERD:INPT}}$$

Note: the displayed value is also affected by the decimal point and display range settings.

INPT (input type)

Displays and sets the input type to be used for period measurement. If set to **Lo** then the instrument will measure the period of an input with a low going edge. If set to **h, 9h** then the instrument will measure the period of an input with a high going edge.

CRST (reset value) - applicable to PEFd mode only.

The reset terminal can be programmed to cause the display to reset to either zero or the selected preset value. Choose either **ZERO** or **P.SET** to select the required operation.

CRST (reset mode)

Allows selection of reset level or edge to force a reset. If set to **Lo** a low input level or closed switch on the reset line will force a reset. If set to **H** a high input level or open switch on the reset line will force a reset. If set to **LoE** then a falling edge or switch closure on the reset line will force a reset. If set to **HE** then a rising edge or switch opening on the reset line will force a reset.

dbnc (debounce)

Displays and sets the debounce time. The debounce time can be set from 0 to 1000 displayed units. If the input pulse width is less than the debounce time setting then the input will be ignored and will not be displayed.

SET QPEF (set operating mode)

Displays and sets the selected operating mode, e.g. select **S.Prd** for scaled period measurement. See the dedicated chapter in this manual for description of the required operating mode. Options are:

S.Prd - Scaled period measurement.

rbc - Not applicable to this manual

PEFd - Period measurement

both - Not applicable to this manual

tbl - Not applicable to this manual

FFEQ - Not applicable to this manual

Serial communication functions

The following serial communications functions apply only if the serial communications option is fitted. Refer to the separate "RM4 Panel Meter Optional Output Addendum" booklet supplied when this option is fitted.

baud (set baud rate). Refer to the separate "RM4 Panel Meter Optional Output Addendum" booklet supplied when this option is fitted.

Select from **300 . 600 . 1200 . 2400 . 4800 . 9600 . 19.2** or **38.4**.

Prty (set parity). Refer to the separate "RM4 Panel Meter Optional Output Addendum" booklet supplied when this option is fitted.

Select parity check to either **none**, **even** or **odd**.

Q.Pnt (set RS232/485 interface mode). Refer to the separate "RM4 Panel Meter Optional Output Addendum" booklet supplied when this option is fitted.

Select **d, SP, Cont, POLL** or **̄.buS**

Allows user to select the RS232/485 interface operation as follows:-

d, SP Sends image data from the display without conversion to ASCII.

Cont Sends ASCII form of display data every time display is updated.

POLL Controlled by computer or PLC as host. Host sends command via RS232/485 and instrument responds as required.

̄.buS Modbus RTU protocol.

Addr (set unit address for polled (POLL) mode (0 to 31)). Refer to the separate "RM4 Panel Meter Optional Output Addendum" booklet supplied when this option is fitted.

Allows several units to operate on the same RS485 interface reporting on different areas etc. The host computer or PLC may poll each unit in turn supplying the appropriate address. The unit address ranges from 0 to 31 (DEC) but is offset by 32 (DEC) to avoid clashing with ASCII special function characters (such as <STX> and <CR>). Therefore 32 (DEC) or 20 (HEX) is address 0, 42 (DEC) or 2A (HEX) addresses unit 10.

Returning to the normal measure mode

When the calibration procedure has been completed it is advisable to return the instrument to the normal mode (where calibration functions cannot be tampered with). To return to the normal mode, turn off power to the instrument, wait a few seconds and then restore power.

5.2 Scaled period measurement examples

Examples of using **PERd : NPt** and **PERd SCLE**.

The actual period of the input pulse (seconds) is used with the **PERd : NPt** and **PERd SCLE** functions to scale the display value. Normal and reciprocal modes are available. The formulae for each type are as below.

For normal mode (PLSE or SngL)

$$\text{Display Value} = \frac{\text{input period (seconds)} \times \text{PERd SCLE}}{\text{PERd : NPt}}$$

i.e. the display value is proportional to the input period of the pulse and the display is scaled by the **PERd : NPt** and **PERd SCLE** functions. input period (seconds) x PERd SCLE

For reciprocal mode (PLS.F or Sng.F)

$$\text{Display Value} = \frac{\text{PERd SCLE}}{\text{input period (seconds)} \times \text{PERd : NPt}}$$

i.e. the display value is inversely proportional to the input period of the pulse and the display is scaled by the **PERd : NPt** and **PERd SCLE** functions.

Example 1 - Using normal mode

The input pulse is the time an object takes to move over a distance of 100mm. Display is to show time taken in seconds with a resolution of 0.1 milliseconds.

Set the decimal point (**dCPt**) to **0.1**. Set period scale to **1000.0** (one thousand milli seconds = 1 second) and period input to **1**. The actual period in seconds will be multiplied by 1000.0 and divided by 1 to give a scaled result in milli seconds.

Example 2 - Using reciprocal mode

For the same inputs given in Example 1 it is required to display velocity in metres per second with a resolution of 0.01 metres per second.

Set the decimal point (**dCPt**) to **0.02**. Set period scale to **1.00** and period input to **10** (100mm in 0.1 seconds = 1m/s). The period scale of 1.0 will be divided by the product of the input period in seconds and the period input to give a display scaled in metres/sec. So for 100mm travelled in 0.1 second the display value = $1.00 / (0.1 \times 10) = 1\text{m/s}$

Example 3 - Using reciprocal mode

For the same inputs as Example 2 it is now required to scale the instrument to read in kilometres per hour.

Set period input to **100.00** (ten thousand times 100mm = one kilometre but this number is divided by 100 to allow it to fit onto the display) and period scale to **36** (three thousand, six hundred seconds in one hour divided by 100 to maintain the same ratio as the period input).

5.3 Function table - scaled period mode

Initial display	Meaning of display	Next display	Default Settings	Record Your Settings
RxLo	Alarm low setpoint value	Setpoint value or OFF	OFF	
RxHi	Alarm high setpoint value	Setpoint value or OFF	OFF	
RxHy	Alarm hysteresis	0 to 5000	10	
Rxtt	Alarm trip time	0 to 9999	0	
Rxrt	Alarm reset time	0 to 9999	0	
Rxn.o/Rxn.c	Alarm action N/O or N/C	Rxn.o or Rxn.c	Rxn.o	
RxSP or Rxtt etc.	Setpoint or trailing alarm	RxSP or Rxtt etc	RxSP	
brgt	Digital display brightness	0 to 15 (15 = highest brightness)	15	
dULL	Remote input brightness control	0 to 15 (15 = highest brightness)	0	
FEC-	Analog retransmission low value	Value in memory	0	
FEC+	Analog retransmission high value	Value in memory	1000	
The functions below are accessible only via CAL mode or if the ACCS function is set to ALL				
d.OFF SECS	Display auto dimming timer (seconds)	0 to 9999	0	
drnd	Display rounding, selects resolution	Value in memory	1	
r.i NP	Remote input	NONE . P.HLd . d.HLd . H. . Lo . Hi . Lo . 2EFG . SP . RC . No . RC . di . SP . dULL or 9.rSt	NONE	
P.but	 Button operation	NONE . H. . Lo . H . Lo . 2EFG . di . SP or P . SEt	NONE	
ACCS	Access mode	OFF . ERSY . NONE or ALL	OFF	
SPAC	Setpoint access	R1 . R1-2 etc.	R1	
dCPE	Decimal point place	0 . 0 . 1 . 0.002 etc	0	
OPER	Set operating mode	PLSE . 5n9.L . PLS.F or 5n9.F	PLSE	
PERdi NPt	Period input scale factor	Value in memory	1	
PERd SCLF	Period scale factor	Value in memory	1	
i NPt	Input edge type	Lo or hi . 9h	Lo	
c.rSt	Reset value	2EFG or P . SEt	2EFG	
c.rSt	Reset mode	Lo . H. . LoE or H. . E	Lo	
dbnc	Debounce time (mS)	0 to 9999	0	
SEt OPER	Set operating mode	5 . Prd . rtc . PEFd . both . bothL or FFEQ	PEFd	
baud RATE	Baud rate.	300 . 600 . 1200 . 2400 . 4800 . 9600 . 19.2 or 38.4	9600	
Prty	Parity select.	NONE . EUEN or Odd	NONE	
OPut	Output, continuous or controlled.	POLL . Cont or di . SP	POLL	
Addr	Set unit address for POLL mode.	0 to 31	0	

Functions shaded will be seen only when those options are fitted.

6 Specifications

6.1 Technical Specifications

Input:	Link selectable internal pull up resistor, internal pull down resistor, biased input, DC couple and 2V added hysteresis. For inductive, AC and square wave inputs the maximum input voltage is 48VDC or RMS with appropriate link settings
Timer functions:	Period or scaled period mode
Accuracy:	Period measurement 0.01% \pm 10uS
Impedance:	10K Ω
Max count rate:	100kHz
Memory retention:	Time memory retained for a minimum of forty days with power removed.
Reset:	Reset via contact closure (or 5V control voltage) across terminals 6 & 9.
Microprocessor:	MC68HC11 CMOS.
Ambient temperature:	-10 to 60°C.
Humidity:	5 to 95% non condensing.
Display:	LED 5 digit 7.6mm + alarm annunciator LEDs
Power Supply:	AC 240V, 110V, 24V or 32V 50/60Hz. DC 12 to 48V wide range.
Power consumption:	AC supply 4 VA max, DC supply, consult supplier (depends on options fitted).
Output (standard):	2 x relays, form A rated 5A resistive 240VAC 5V or 24VDC unregulated transmitter supply (common ground) rated at 25mA, available on both AC and DC powered models.

6.2 Output Options

Third Relay:	Rated 0.5A resistive 30VAC or DC. May be configured for either form A or form C if the third relay is the only option fitted.
Fourth Relay:	Rated 0.5A resistive 30VAC or DC, form A.
Switched Voltage:	Non isolated 24VDC output to be used for open collector or solid state relay driver output.
Analog Retransmission:	Isolated 4 to 20mA or 0 - 1V or 0 - 10V link selectable, 12 bit or 16 bit versions available. Configurable as retransmission or PI control.
Serial Communications:	RS232, RS485 or RS422 factory configured
Transmitter supply:	Isolated & regulated. Link selectable 12VDC (50mA max) or 24VDC (25mA max)

6.3 Physical Characteristics

Case Size:	44mm (w) x 91mm (h) x 141mm (d)
Connections:	Plug in screw terminals (max 1.5mm ² wire for input signal and options 2.5mm ² for power and relays 1 & 2)
Weight:	470 gms basic model, 500 gms with option card

Guarantee and Service

The product supplied with this manual is guaranteed against faulty workmanship for a period of 2 years from the date of dispatch.

Our obligation assumed under this guarantee is limited to the replacement of parts which, by our examination, are proved to be defective and have not been misused, carelessly handled, defaced or damaged due to incorrect installation. This guarantee is VOID where the unit has been opened, tampered with or if repairs have been made or attempted by anyone except an authorised representative of the manufacturing company.

Products for attention under guarantee (unless otherwise agreed) **must be returned to the manufacturer freight paid** and, if accepted for free repair, will be returned to the customers address in Australia free of charge.

When returning the product for service or repair a full description of the fault and the mode of operation used when the product failed must be given.

In any event the manufacturer has no other obligation or liability beyond replacement or repair of this product.

Modifications may be made to any existing or future models of the unit as it may deem necessary without incurring any obligation to incorporate such modifications in units previously sold or to which this guarantee may relate.

**This document is the property of
the instrument manufacturer
and may not be reproduced in whole or part without the
written consent of the manufacturer.**

This product is designed and manufactured in Australia.