

PM4-RT
Temperature
Process Monitor/Controller
Operation and Instruction Manual
(inputs from RTDs,
LM335 & AD590 sensors)

Table of Contents

Introduction	3
Mechanical Installation	4
Electrical Installation	5
Power supply connections	6
Input sensor wiring	6
Relay connections	6
Input link settings.	6
Explanation of Functions	7
Function Table for fully optioned instrument.	17
Input/Output Configuration	19
Specifications.	20
Setting up the relay PI controller	21
Guarantee and Service	28

1 Introduction

This manual contains information for the installation and operation of the PM4-RT Monitor. The PM4 is a general purpose temperature monitor which may be configured to accept inputs from 100Ω and 1000Ω RTDs, LM335 and AD590 temperature sensors. The instrument may be calibrated to display the temperature in °C or °F . A standard inbuilt relay provides an alarm/control function, optional extra relays, retransmission and excitation voltage may also be provided. Refer to the separate “PM4 Panel Meter Optional Output Addendum” booklet supplied when optional outputs are fitted.

Unless otherwise specified at the time of order, your PM4 has been factory set to a standard configuration. Like all other PM4 series instruments the configuration and calibration is easily changed by the user. Initial changes may require dismantling the instrument to alter PCB links, other changes are made by push button functions.

Full electrical isolation between power supply, input voltage or current and retransmission output is provided by the PM4, thereby eliminating grounding and common voltage problems. This isolation feature makes the PM4 ideal for interfacing to computers, PLCs and other data acquisition devices

The versatile PM4 has various front panel options, therefore in some cases the pushbuttons may be located on the front panel as well as the standard rear panel configuration.

The PM4 series of Panel Mount Monitors are designed for high reliability in industrial applications. The high brightness LED display provides good visibility, even in areas with high ambient light levels. The high contrast LCD displays provide good visibility and are ideal for battery powered applications.

Inputs & outputs

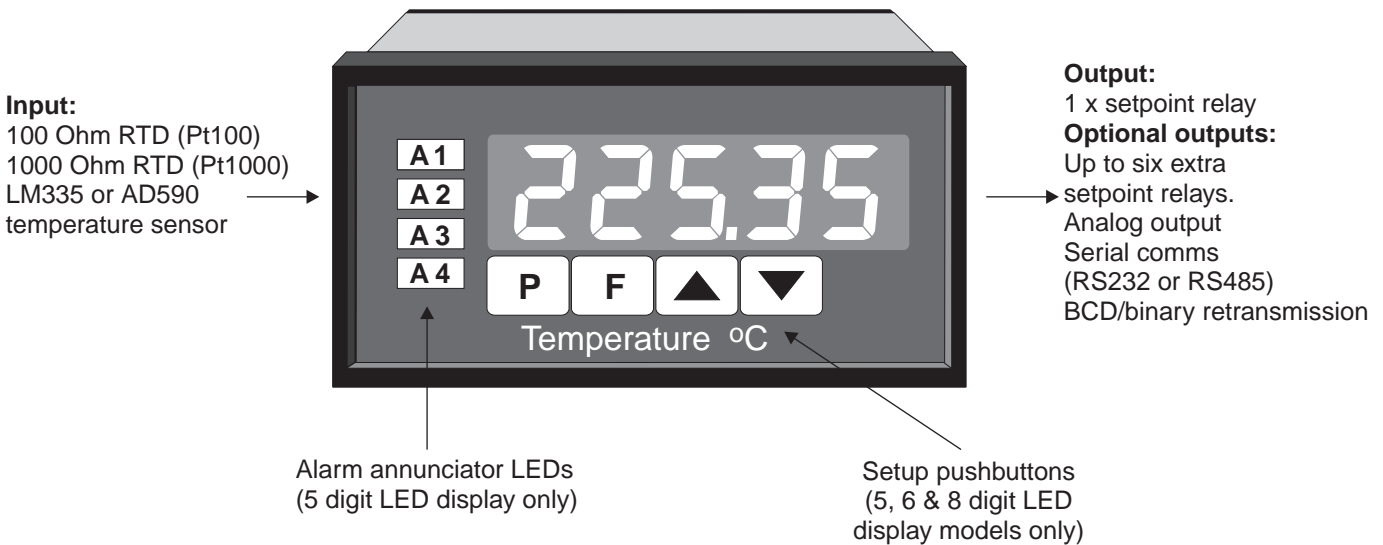

2 Mechanical Installation

If a choice of mounting sites is available then choose a site as far away as possible from sources of electrical noise such as motors, generators, fluorescent lights, high voltage cables/bus bars etc. An IP65 access cover which may be installed on the panel and surrounds is available as an option to be used when mounting the instrument in damp/dusty positions. A wall mount case is available, as an option, for situations in which panel mounting is either not available or not appropriate. A portable carry case is also available, as an option, for panel mount instruments.

Prepare a panel cut out of 45mm x 92mm +1 mm / -0 mm (see diagram below). Insert the instrument into the cut out from the front of the panel. Then, from the rear of the instrument, fit the two mounting brackets into the recess provided (see diagram below). Whilst holding the bracket in place, tighten the securing screws being careful not to over-tighten, as this may damage the instrument.

Hint: use the elastic band provided to hold the mounting bracket in place whilst tightening securing screws.

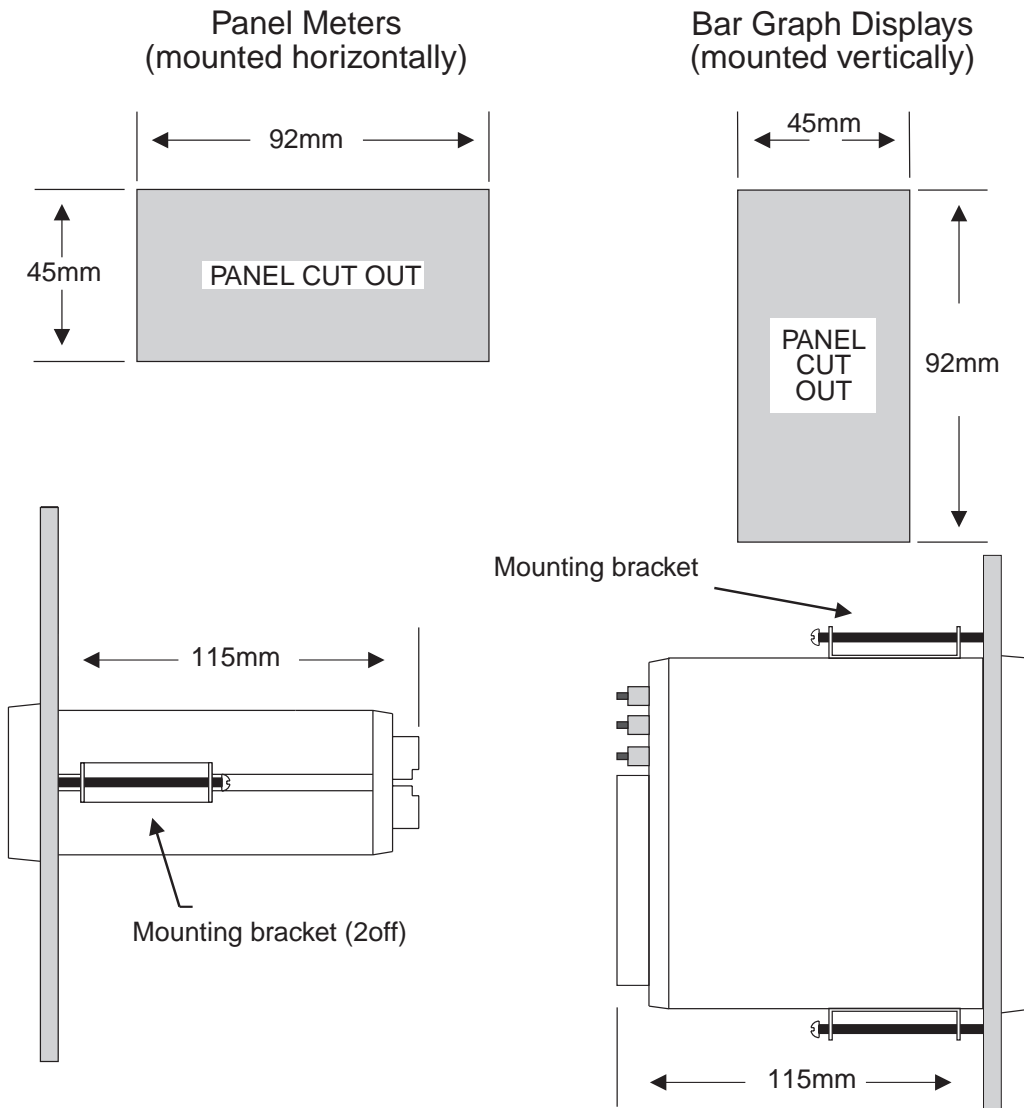

Side view of mounting panel

3 Electrical Installation

The PM4 Panel Meter is designed for continuous operation and no power switch is fitted to the unit. It is recommended that an external switch and fuse be provided to allow the unit to be removed for servicing.

The terminal blocks allow for wires of up to 2.5mm² to be fitted. Connect the wires to the appropriate terminals as indicated below. Refer to other details provided in this manual to confirm proper selection of voltage, polarity and input type before applying power to the instrument. When power is applied the instrument will cycle through a display sequence, indicating the software version and other status information, this indicates that the instrument is functioning. Acknowledgement of correct operation may be obtained by applying an appropriate input to the instrument and observing the resultant reading.

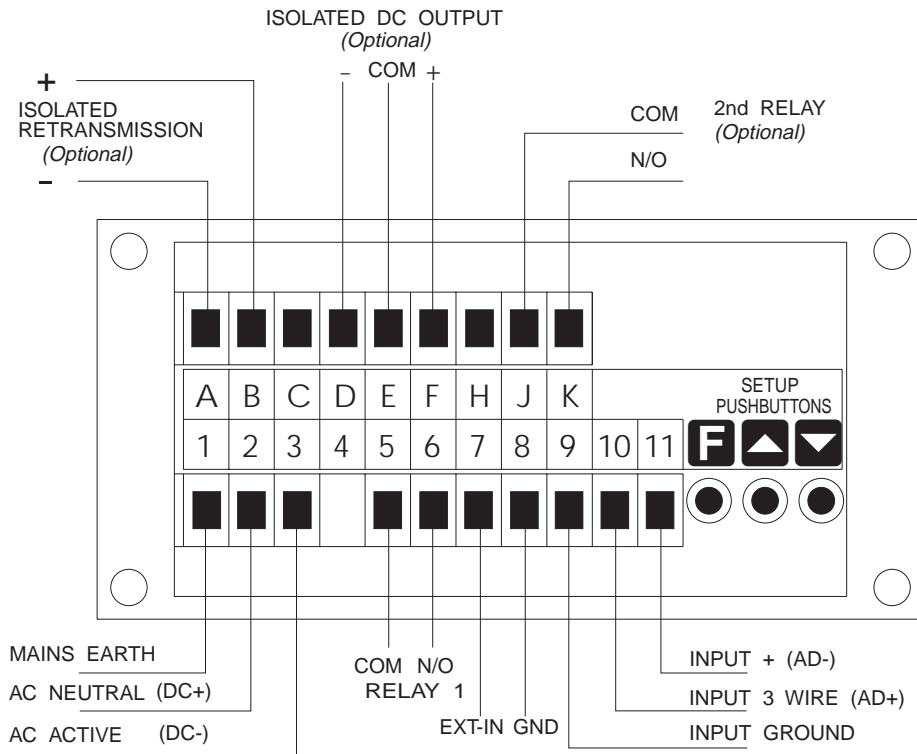

Instrument Rear Panel

		OPTIONAL OUTPUTS	
1	MAINS EARTH	A	OUTPUT V/I -
2	240VAC NEUTRAL	B	OUTPUT V/I +
3	240VAC ACTIVE	C	
4		D	DC VOLTS OUTPUT -
5	RELAY 1 COM	E	DC VOLTS OUTPUT GND
6	RELAY 1 N/O	F	DC VOLTS OUTPUT +
7	EXT INPUT	H	
8	GROUND	J	RELAY 2 COM
9	INPUT GROUND	K	RELAY 2 N/O
10	INPUT 3W (AD590+)		
11	INPUT + (AD590-)		
PM4--RT-240-4E-AR12		SERIAL No:	

Instrument Data Label (example)

3.1 Power supply connections

The power supply for the instrument is factory fitted and is of a fixed type. If you are unsure of the supply requirement for your instrument it can be determined by the model number on the instrument label:-

- PM4-RT-240-..... Requires 240VAC
- PM4-RT-110-..... Requires 110VAC
- PM4-RT-24-..... Requires 24VAC
- PM4-RT-DC-..... Requires between 9 and 55VDC

3.2 Input sensor wiring

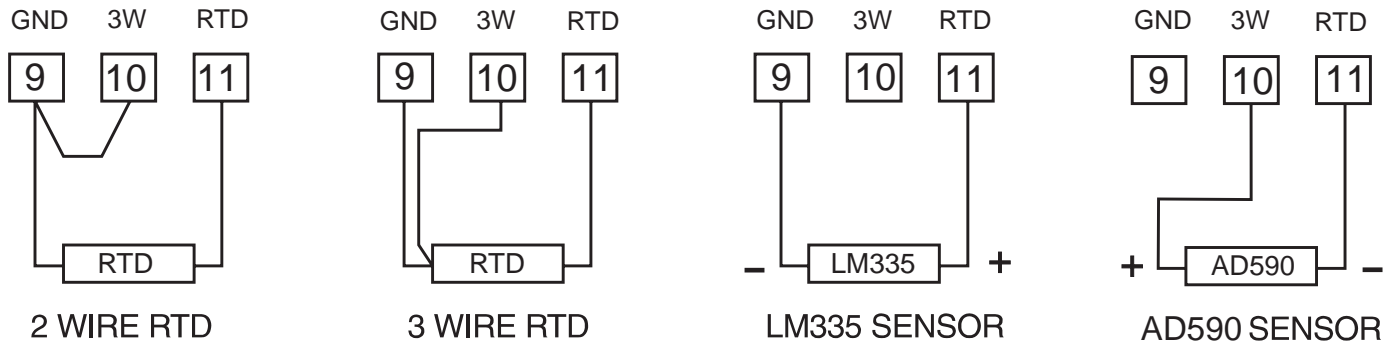

3.3 Relay connections

The PM4 is supplied with one alarm relay as standard with connections on pins 5 and 6, extra relays are optionally available. The relay is a single pole, single throw types and is rated at 5A, 240VAC into a resistive load. The relay contact is voltage free and may be programmed for normally open or normally closed operation.

3.4 Input link settings

See the "Input/Output Configuration" chapter for instructions on removing the input board.

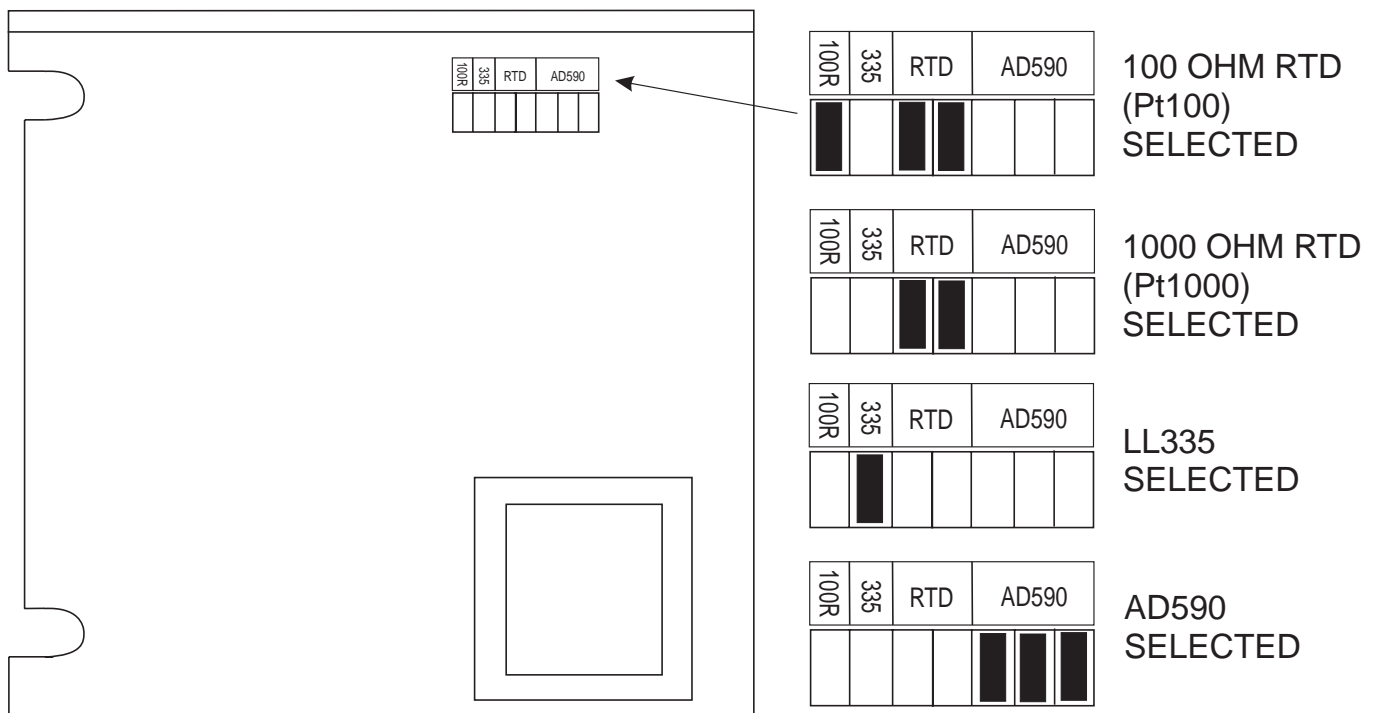

4 Explanation of Functions

The PM4 setup and calibration functions are configured through a push button sequence. Two levels of access are provided for setting up and calibrating:-

FUNC mode (simple push button sequence) allows access to commonly set up functions such as alarm setpoints.

CAL mode (power up sequence plus push button sequence) allows access to all functions including calibration parameters.

The three push buttons located at the rear of the instrument (also at the front on some display options) are used to alter settings. Once **CAL** or **FUNC** mode has been entered you can step through the functions, by pressing and releasing the **F** push button, until the required function is reached. Changes to functions are made by pressing the **▲** or **▼** push button (in some cases both simultaneously) when the required function is reached.

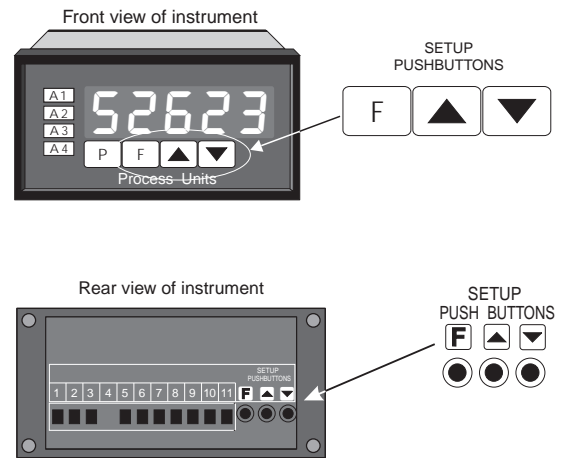

Entering **CAL** Mode



1. Remove power from the instrument. Hold in the **F** button and reapply power. The display will indicate **CAL** as part of the "wake up messages" when the **CAL** message is seen you can release the button.



2. When the "wake up" messages have finished and the display has settled down to its normal reading press, then release the **F** button.

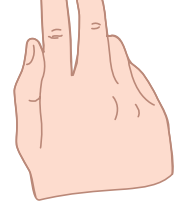

3. Within 2 seconds of releasing the **F** button press, then release the **▲** and **▼** buttons together. The display will now indicate **FUNC** followed by the first function.

Note: If step 1 above has been completed then the instrument will remain in this **CAL** mode state until power is removed. i.e. there is no need to repeat step 1 when accessing function unless power has been removed.

Entering **FUNC** Mode

No special power up procedure is required to enter **FUNC** mode.



1. When the "wake up" messages have finished and the display has settled down to its normal reading press, then release the **F** button.

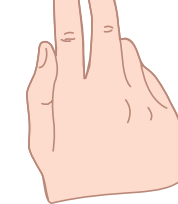

2. Within 2 seconds of releasing the **F** button press, then release the **▲** and **▼** buttons together. The display will now indicate **FUNC** followed by the first function.

The alarm and brightness functions below are accessible via **FUNC** mode.

Note that “x” in the alarm functions is used to indicate any alarm number e.g. if 2 setpoint alarm relays are fitted then **R1Lo** and **R2Lo** will all seen as functions on the display. The functions **RxHy**, **RxLt**, **Rxrt**, **Rxn.o/Rxn.c** and **Rx.SP/t** will only be seen if a high or low setpoint is set.

The PM4 has an easy alarm access facility which allows access to the alarm setpoints simply by pressing the **F** button at the front or rear of the instrument. The first setpoint will then appear and changes may be made to this setpoint via the **▲** or **▼** buttons. Press the **F** button to accept any changes or to move on to the next setpoint.

The instrument must be set in the manner described below to enable the easy access facility (if required):

1. The **F: NP** function must be set to **SP.AC** or the **ALCS** function must be set to **EASY**.
2. At least one alarm must have a setpoint, nothing will happen if all the alarm setpoints are set to **OFF**.
3. The **SP.AC** function must be set to allow access to the relays required e.g. if set to **R1-2** then the easy access will work only with alarm relays 1 and 2 even if more relays are fitted.
4. The instrument must be in normal measure mode i.e. if the instrument is powered up so that it is in **CAL** mode then the easy access will not function. If in doubt then remove power from the instrument, wait for a few seconds then apply power again.
5. If the easy access facility is used then the only way to view or alter any other function settings is to power up via **CAL** mode i.e. no entry to **FUNC** mode unless the instrument is powered up in **CAL** mode.

RxLo (alarm low setpoint)

Displays and sets the low setpoint value for the designated alarm relay. The low alarm setpoint may be disabled by pressing the **▲** and **▼** pushbuttons simultaneously. When the alarm is disabled the display will indicate **OFF**. Use **▲** or **▼** to adjust the setpoint value if required. The alarm will activate when the displayed value is lower than the **RxLo** setpoint value. Each relay may be configured with both a low and high setpoint if required, if so the relay will be activated when the display reading moves outside the band set between low and high setpoints.

RxH. (alarm high setpoint)

Displays and sets the high setpoint value for the designated alarm relay. The high alarm setpoint may be disabled by pressing the **▲** and **▼** pushbuttons simultaneously. When the alarm is disabled the display will indicate **OFF**. Use **▲** or **▼** to adjust the setpoint value if required. The alarm will activate when the displayed value is higher than the **RxH.** setpoint value. Each relay may be configured with both a low and high setpoint if required, if so the relay will be activated when the display reading moves outside the band set between low and high setpoints.

RxHy (alarm hysteresis [deadband])

Displays and sets the alarm hysteresis limit and is common for both high and low setpoint values. The hysteresis value may be used to prevent too frequent operation of the setpoint relay when the measured value stays close to the setpoint. Without a hysteresis setting (**RxHy** set to zero) the alarm will activate when the display value goes above the alarm setpoint (for high alarm) and will reset when the display value falls below the setpoint, this can result in repeated on/off switching of the relay at around the setpoint value. The hysteresis setting operates as follows:

In the high alarm mode, once the alarm is activated the input must fall below the setpoint value minus the hysteresis value to reset the alarm. e.g. if **R1H.** is set to **50.0** and **R1Hy** is set to **3.0** then the setpoint output relay will activate once the display value goes above **50.0** and will reset when the display value goes below **47.0** (50.0 minus 3.0).

In the low alarm mode, once the alarm is activated

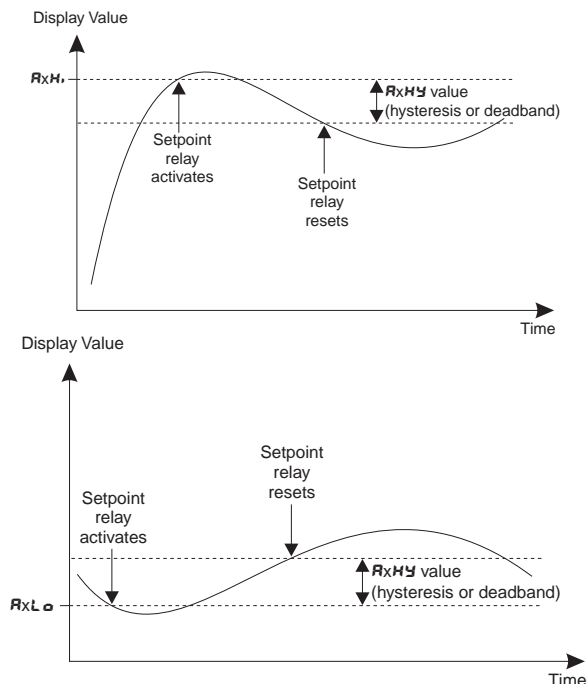

the input must rise above the setpoint value plus the hysteresis value to reset the alarm.
 e.g. if **A L₀** is set to **20.0** and **A H₄** is set to **10.0** then the alarm output relay will activate when the display value falls below **20.0** and will reset when the display value goes above **30.0** (20.0 plus 10.0).

The hysteresis units are expressed in displayed engineering units.

A_xt_t (alarm trip time)

Displays and sets the alarm trip time and is common for both alarm high and low setpoint values. The trip time is the delay time before the alarm relay will activate, or trip, when an alarm condition is present. The alarm condition must be present continuously for the trip time period before the alarm will trip. This function is useful for preventing an alarm trip due to short non critical deviations from setpoint. The trip time is selectable over **0** to **60** seconds.

A_xr_t (alarm reset time)

Displays and sets the alarm relay reset time. With the alarm condition is removed the alarm relay will stay in its alarm condition for the time selected as the reset time. The reset time is selectable over **0** to **60** seconds.

A_xn._o or A_xn._c (alarm x normally open or normally closed)

Displays and sets the setpoint alarm relay action to normally open (de-energised) or normally closed (energised), when no alarm condition is present. A normally closed alarm is often used to provide a power failure alarm indication.

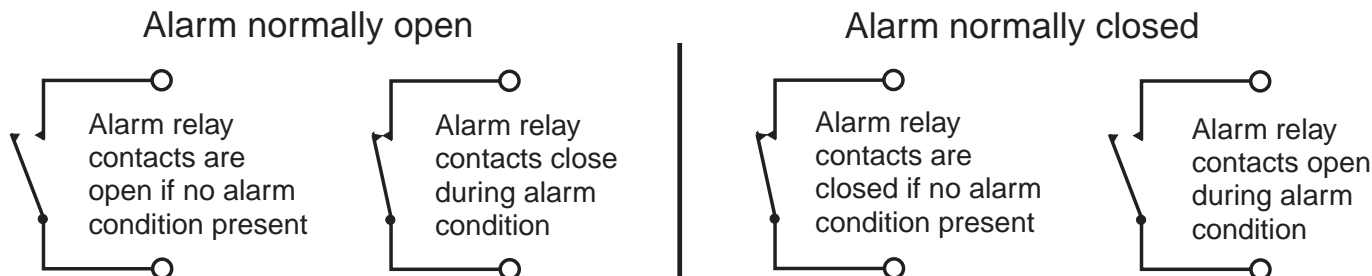

A_x.SP, A_x.t₁, A_x.t₂ etc. (relay operation independent setpoint or trailing setpoint)

Each alarm may be programmed to operate with an independent setpoint setting or may be linked (or trailing) to operate at a fixed difference to another relay setpoint. The operation is as follows: Alarm 1 (**A₁**) is always independent. Alarm 2 (**A₂**) may be independent or may be linked to Alarm 1. Alarm 3 (**A₃**) may be independent or may be linked to Alarm 1 or Alarm 2. Alarm 4 (**A₄**) may be independent or may be linked to Alarm 1, Alarm 2 or Alarm 3. The operation of each alarm is selectable within the Function Setup Mode by selecting, for example, (Alarm 4) **A₄.SP** = Alarm 4 normal setpoint or **A₄.t₁** = Alarm 4 trailing Alarm 1 or **A₄.t₂** = Alarm 4 trailing Alarm 2 or **A₄.t₃** = Alarm 4 trailing Alarm 3. For trailing set points the setpoint value is entered as the difference from the setpoint being trailed. If the trailing setpoint is to operate ahead of the prime setpoint then the value is entered as a positive number and if operating behind the prime setpoint then the value is entered as a negative number. For example, with Alarm 2 set to trail alarm 1, if **A₁H** is set to 1000 and **A₂H** is set to 50 then Alarm 1 will activate at 1000 and alarm 2 will activate at 1050 (i.e. 1000 + 50). If Alarm 2 had been set at -50 then alarm 2 would activate at 950 (i.e. 1000 - 50). See the trailing alarm table which follows.

Trailing Alarm Table Showing Possible Alarm Assignments						
	A₂	A₃	A₄	A₅	A₆	A₇
A₁	A₂.t₁	A₃.t₁	A₄.t₁	A₅.t₁	A₆.t₁	A₇.t₁
A₂		A₃.t₂	A₄.t₂	A₅.t₂	A₆.t₂	A₇.t₂
A₃			A₄.t₃	A₅.t₃	A₆.t₃	A₇.t₃
A₄				A₅.t₄	A₆.t₄	A₇.t₄
A₅					A₆.t₅	A₇.t₅
A₆						A₇.t₆

Rx OPEr (alarm relay operating mode)

This function allows selection of standard alarm on/off setpoint operation (**Rx.RL**) using the alarm functions described in this chapter or PI control operation (**RxLP** or **RxFr**). Refer to the "Setting up the relay PI controller" appendix for details of the PI control operations and functions.



br 9t (display brightness)

Displays and sets the digital display brightness. The display brightness is selectable from **1** to **15**, where **1** = lowest intensity and **15** = highest intensity. This function is useful for improving the display readability in dark areas or to reduce power consumption.



dULL (remote display brightness)

Displays and sets the level for remote input brightness switching, see **r.i NP** function. When the remote input is set to **dULL** the remote input can be used to switch between the display brightness level set by the **br 9t** function and the display brightness set by the **dULL** function. The display brightness is selectable from **0** to **15**, where **0** = lowest intensity and **15** = highest intensity. This function is useful in reducing glare when the display needs to be viewed in both light and dark ambient light levels.

r EC - (recorder/retransmission output low value) - seen only when analog output option fitted. Refer to the separate "PM4 Panel Meter Optional Output Addendum" booklet supplied when this option is fitted.

Displays and sets the analog retransmission (4-20mA, 0-1V or 0-10V, link selectable) output low value (4mA or 0V) in displayed engineering units. e.g. if it is required to retransmit 4mA when the display indicates **0** then select **0** in this function via the  or  button.

r EC ~ (recorder/retransmission output high value) - seen only when analog output option fitted. Refer to the separate "PM4 Panel Meter Optional Output Addendum" booklet supplied when this option is fitted.



Displays and sets the analog retransmission (4-20mA, 0-1V or 0-10V, link selectable) output high value (20mA, 1V or 10V) in displayed engineering units. e.g. if it is required to retransmit 20mA when the display indicates **500** then select **500** in this function via the  or  button.

The functions which follow are accessible via **LR mode only.**

drnd (display rounding)

Displays and sets the display rounding value. This value may be set to 0 - 5000 displayed units. Display rounding is useful for reducing the instrument resolution without loss of accuracy, in applications where it is undesirable to display to a fine tolerance. (example if set to **10** the instrument will display in multiples of 10).

dCPt (decimal point selection)

Displays and sets the decimal point. By pressing the  or  pushbuttons the decimal point position may be set. The display will indicate as follows: **0** (no decimal point), **0.1** (1 decimal place) or **0.02** (2 decimal places).

FLtr (digital filter)

Displays and sets the digital filter value. Digital filtering is used for reducing susceptibility to short term interference. The digital filter range is selectable from **0** to **8**, where **0** = none and **8** = most filtering. A typical value for the digital filter would be **3**.

rtd tYPE (temperature sensor type)

Displays and selects the input sensor type being used.

Select from **100** (100 Ω RTD or PT100), **1000** (1000 Ω RTD or PT1000), **L335** (LM335 semiconductor sensor) or **A590** (AD590 semiconductor sensor).

dEG tYPE (display units °C or °F)

Displays and sets the display temperature units. Select **°C** or **°F**.

di SP unit (display unit)

Allows selection of **NONE** (no units appear on the display), **°C** (e.g. **21.0°C** display) or **°F** (e.g. **53°F** display).

FEECETRI (analog output mode) - seen only when analog output option is fitted. Refer to the separate "PM4 Panel Meter Optional Output Addendum" booklet supplied when this option is fitted.

This function allows selection of **ON** or **OFF** for PI control output. If set to **OFF** the analog output operates as a retransmission output and uses the functions described in this chapter. If set to **ON** the analog output operates as a PI control output, refer to the "Setting up the analog PI controller" appendix for details of PI control operation and functions.

bARr - (bar graph display low value) - seen only in bargraph display instruments. Displays and sets the bar graph low value i.e. the value on the 7 segment display at which the bargraph will start to rise. This may be independently set anywhere within the display range of the instrument.

Note: The **bARr -** and **bARr +** settings are referenced from the 7 segment display readings, not the bargraph scale values. The bargraph scale may scaled differently to the 7 segment display, as shown on the right where bargraph scale is 0 to 100 yet the display is showing **475.3**. In this example the bargraph scale may be indicating a percentage whilst the 7 segment display is indicating actual temperature.

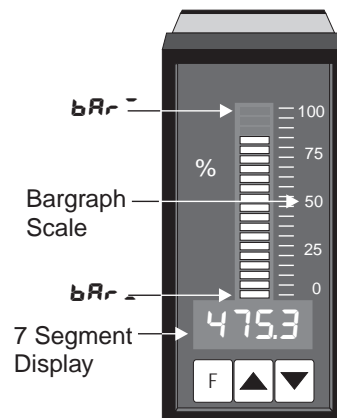

bARr + (bargraph display high value) - seen only in bargraph display instruments.

Displays and sets the bar graph high value i.e. the value on the 7 segment display at which the bargraph will reach its maximum indication (all LED's illuminated). May be independently set anywhere within the display range of the instrument.

bARr TYPE (bar graph display operation mode)

Seen only in bargraph display instruments. Allows selection of bargraph operation mode choices are:

bARr - conventional solid bargraph display i.e. all LED's illuminated when at full scale.

When scaling the display use the **bARr -** and **bARr +** functions e.g. **bARr - = 0** and **bARr + = 100** will give a bargraph with no segments lit at a 7 segment display reading of **0** and all segments lit with a 7 segment display reading of **100**.

S.dot - single dot display. A single segment will be lit to indicate the input readings position on the scale.

When scaling the display use the **bARr -** and **bARr +** functions e.g. **bARr - = 0** and **bARr + = 100** will give a bargraph with the bottom segment lit at a 7 segment display reading of **0** and the top segment lit with a 7 segment display reading of **100**.

Note: this could also be set up as a centre zero single dot display by entering a negative value and positive value. e.g. **bARr - = - 100** . **bARr + = 100**.

d.dot - double dot display. Two segments will be lit to indicate the input reading position on the scale. The reading should be taken from the middle of the two segments.

When scaling the display use the **bARr -** and **bARr +** functions e.g. **bARr - = 0** and **bARr + = 100** will give a bargraph with the bottom two segments lit at a 7 segment display reading of **0** and the top two segments lit with a 7 segment display reading of **100**.

Note: this could also be set up as a centre zero single dot display by entering a negative value and positive value. e.g. **bARr - = - 100** . **bARr + = 100**.

C.bARr - centre bar display. The display will be a solid bargraph but will have its zero point in the middle of the display. If the seven segment display value is positive the bargraph will rise. If the seven segment display value is negative then the bargraph will fall.

When scaling the display use the **bARr -** and **bARr +** functions e.g. **bARr - = 0** and **bARr + = 100** will give a bargraph with all the bottom half segments lit at a 7 segment display reading of **- 100** and all the top segments lit with a 7 segment display reading of **100**.

d9.OP (digital output operating mode) - seen only with digital output option. Refer to the separate "PM4 Panel Meter Optional Output Addendum" booklet supplied when this option is fitted.

Select from **b, n2** - signed binary output, **b, n** - unsigned binary output, **b, 5CL** - scaled binary output, **bcd** - BCD output.

d9.OP (output polarity) - seen only with digital output option. Refer to the separate "PM4 Panel Meter Optional Output Addendum" booklet supplied when this option is fitted.

Select either **RI 0** - active low output or **RI 1** - active high output.

bcd 5trt (BCD - start display position) - seen only with digital output option. Refer to the separate “PM4 Panel Meter Optional Output Addendum” booklet supplied when this option is fitted.

This function affects BCD mode only and determines the number of digits to skip when outputting from the display. Select from 0 to number of display digits minus 4. e.g. for a 6 digit display you may select 0 to 2, if 2 is selected then the four left most digits will be output.

d, 9- (scaled digital output low reading) - seen only with digital output option. Refer to the separate “PM4 Panel Meter Optional Output Addendum” booklet supplied when this option is fitted.

Accepts any valid display value. Determines the low scaling point for the **b.5CL** mode and has no effect on other modes.

d, 9+ (scaled digital output high reading) - seen only with digital output option. Refer to the separate “PM4 Panel Meter Optional Output Addendum” booklet supplied when this option is fitted.

Accepts any valid display value. Determines the high scaling point for the **b.5CL** mode and has no effect on other modes. For example if **d, 9-** is set to **0** and **d, 9+** is set to **55535** (2^{16}) then the retransmission will not be scaled i.e. a display of **2** will cause a retransmission of 2. If **d, 9+** is now changed to **32767** (2^{15}) then a display of **2** will cause a retransmission of 4.

CAL dE9 (temperature calibration)

To alter the instruments calibration values the instruments functions must be entered via **CAL** mode. The temperature calibration function should only be entered when a new temperature calibration is required. The calibration procedure is as follows:

- A. Place the temperature sensor and a reference thermometer in a suitable heat source.
- B. Enter the calibration function by pressing the **▲** and **▼** buttons simultaneously at the **CAL dE9** function prompt. The display will now indicate a “live” temperature reading.
- C. When the reading has stabilised press the **F** button and note the reading on the reference thermometer. The display will indicate **dE9** followed by the scale value in memory.
- D. Use the **▲** or **▼** button to obtain the required scale (calibration) value i.e. the temperature measured by the reference thermometer.
- E. Press the **F** button, the display will now read **CAL End** indicating that the calibration is complete.

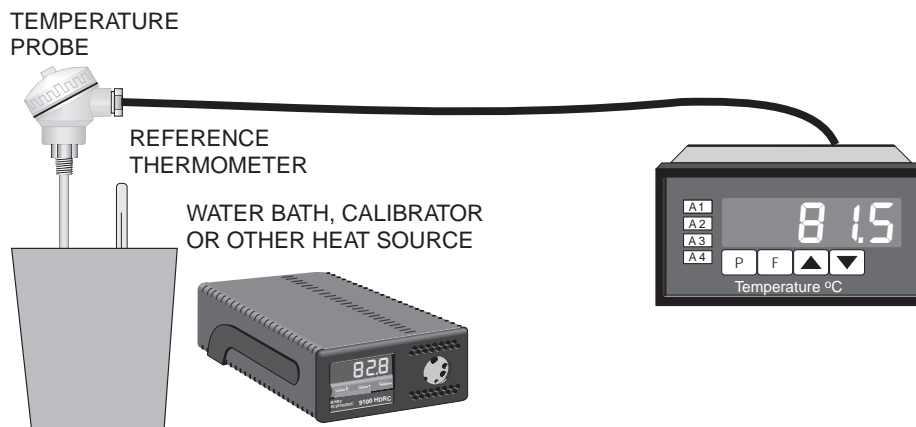

UCAL (uncalibration)

Used to set the instrument back to the factory calibration values. This function is only used when calibration problems exist and the calibration memory needs to be cleared, other settings are not affected. To uncalibrate press the **▲** and **▼** buttons simultaneously, the display will show **CAL CLR** to indicate that the uncalibration is complete.

P.but (P button function)

Applicable only in models with front panel **P** buttons. The **P** button may be set to operate some of the remote input functions, see **r.i NP** below for a description of these functions. The **P** button is located at the front of 5 or 6 digit LED models. If both the remote input and **P** button function are operated simultaneously the **P** button will override the remote input. The functions below are as described in the **r.i NP** function above with the exception of the **P.SET** function.

Functions available are: **NONE, H, Lo or H, Lo**

F.1 RP (remote input function)

Pins 7 and 8 at the rear of the instrument are the remote input pins. When these pins are short circuited, via a pushbutton or keyswitch the instrument will perform the selected remote input function. A message will flash to indicate which function has been selected when the remote input pins are short circuited. The remote input functions are as follows:

NONE - no remote function required.

PHld - peak hold. The display will show the peak value only whilst the remote input pins are short circuited.

d.Hld - display hold. The display value will be held whilst the remote input pins are short circuited.

H - peak memory. The peak value stored in memory will be displayed if the remote input pins are short circuited, if the short circuit is momentary then the display will return to normal measurement after 20 seconds. If the short circuit is held for 1 to 2 seconds or the power is removed from the instrument then the memory will be reset.

Lo - valley memory. The minimum value stored in memory will be displayed. Otherwise operates in the same manner as the **H** function.

H, Lo - toggle between **H** and **Lo** displays. This function allows the remote input to be used to toggle between peak and valley memory displays. The first operation of the remote input will cause the peak memory value to be displayed, the next operation will give a valley memory display. **PH** or **PLo** will flash before each display to give an indication of display type.

SP.Ac - setpoint access only. This blocks access to any functions except the alarm setpoint functions unless the remote input pins are short circuited or entry is made via **CAL** mode.

No.Ac - no access. This blocks access to all functions unless the remote input pins are short circuited or entry is made via **CAL** mode.

CAL.S - calibration select. Two sets of certain setup values can be entered in, one set with the remote input open circuit and another set with the remote input short circuit to ground. The remote input can then be used to switch between one set and the other. This feature provides a simple switch change-over to allow toggling between displays with different function settings for degree type display °C or °F (**DEStYPE**), decimal point place (**dCPlt**), display rounding (**drnd**) or display units (**di SP**) the calibration scaling can also be switched i.e. different **CAL DEG** scale settings can be used. Note: other functions such as the alarm and retransmission settings cannot be changed between the two selections but will function for whichever selection is displayed at the time.

dULL - display brightness control. The remote input can be used to change the display brightness. When this mode is selected the display brightness can be switched, via the remote input, between the brightness level set at the **brgt** function and the brightness level set at the **dULL** function.

ACCESS (access mode)

The access mode function **ACCESS** has four possible settings namely **OFF**, **EASY**, **NONE** and **ALL**. If set to **OFF** the mode function has no effect on alarm relay operation. If set to **EASY** the easy alarm access mode will be activated, see details prior to the **RxLo** function described earlier in this chapter. If set to **NONE** there will be no access to any functions via **FUNC** mode, entry via **CAL** mode must be made to gain access to alarm and calibration functions. If set to **ALL** then access to all functions, including calibration functions, can be gained via **FUNC** mode.

SPAC (setpoint access)

Seen only if more than 1 relay fitted.

Sets the access to the alarm relay set points. The following choices are available:

R 1 - Allows setpoint access to alarm 1 only.

R 1-2 - Allows access to alarms 1 and 2 only.

R 1-3 allows access to alarms 1,2 and 3 etc. up to the maximum number of relays fitted.

The remote input function (**F.1 RP**) must be set to **SP.AC** for this function to operate. Note: Only the setpoints which have been given a value will be accessible e.g. if **R 1H** is set to **OFF** then there will be no access to the **R 1H** function when **SPAC** is used.

Alarm, bargraph and retransmission operation modes

The following describes the output modes for alarm, bargraph, analog and digital retransmission. The serial output (RS232 or RS485) is controlled via polling commands. Refer to the separate "PM4 Panel Meter Optional Output Addendum" booklet supplied when this option is fitted.. The following commands only apply if the option is fitted to the instrument.

R 1, R2 etc. (Alarm relay operation mode for relays 1, 2 etc.).

The following choices are available for alarm operation mode:

L, UE - live input mode. The alarm relay operation will always follow the electrical input at that time irrespective of the 7 segment display value. e.g. assume the remote input is set to **PHLD** and **R 1Lo** is set to **100**. The display may be indicating a peak reading of **500** but if the electrical input changes to correspond with a normal display value of 100 or less then the alarm will operate. This will be the normal setting used unless one of the special modes which follow is required.

P.HLD - peak hold mode. If the peak hold mode is used and the remote input is set to peak hold then once the peak display goes above any alarm high setpoint the alarm relay will activate and will not de-activate until the peak hold is released and the display value falls below the setpoint value.

d.HLD - display hold mode. If the display hold mode is used and the remote input is set to display hold then the alarm relay will be held in its present state (activated or de-activated) until the display hold is released and the display is free to change.

H - peak (max.) memory mode. If the peak memory mode is used and the remote input is set to peak memory then the alarm will be activated if the peak memory value is above the high setpoint value. The alarm will not de-activate until the memory is reset.

Lo - valley (min.) memory mode. If the valley memory mode is used and the remote input is set to valley memory then the alarm relay will be activated if the valley memory value is below the low setpoint value. The alarm will not de-activate until the memory is reset.

d: SP - display mode. If the display mode is used then the alarms will operate purely on the display value at the time i.e. if the display is showing above high setpoint or below the low setpoint value then the alarm relay will activate. For example if the remote input were set to peak memory and **R 1** were set to live display mode then, unless the display is actually showing the peak memory value (i.e. the remote input has just been activated), the alarm relay is free to operate from the changing display value i.e. the memory does not have to be reset to clear an alarm condition.

bAR (bargraph operation mode) - applicable only to bargraph displays.

The following choices are available for bargraph operation mode:

L, UE - live input mode. The bargraph will respond to the electrical input only and will not necessarily follow the 7 segment display value. For example if the remote input is set for peak hold operation then when the remote input is closed the 7 segment display will only show the peak value but the bargraph will be free to move up and down to follow the electrical input. This will be the normal setting used unless one of the special modes which follow is required.

P.HLD - peak hold mode. The bargraph (and 7 segment display) will indicate the peak value only whilst the peak value function is operated via a contact closure on the remote input i.e. the bargraph & 7 segment display can rise but not fall whilst the remote input switch is closed. When the remote input switch is opened the bargraph value will remain fixed i.e. it will not rise or fall, although the 7 segment display value will be free to alter. This peak bargraph reading can be cleared by closing the remote input switch for another operation or by removing power from the instrument. Note: In this mode the bargraph will show a zero reading until the remote input is operated for the first time after switch on.

d.HLD - display hold mode. The bargraph (and 7 segment display) value will be held whilst the remote input display hold switch is closed. When the switch is opened the bargraph value will remain fixed at the held value although the 7 segment display value will be free to alter. The held bargraph reading can be cleared by closing the remote input switch for another operation or by removing power from the instrument. Note: In this mode the bargraph will show a zero reading until the remote input is operated for the first time after switch on.

H - peak (max.) memory mode. With the peak remote input switch open the bargraph will indicate the peak value in memory i.e. the bargraph can rise but not fall. The bargraph can be reset by clearing the memory. The memory may be cleared either by closing the remote input switch for approximately 2 seconds or by removing power.

Lo - valley (min.) memory mode. With the valley remote input switch open the bargraph will indicate the valley (min.) value in memory i.e. the bargraph can fall but not rise. The bargraph can be reset by clearing the memory. The memory may be cleared either by closing the remote input switch for approximately 2 seconds or by removing power.

d: SP - display mode. The bargraph display will follow whatever value is on the 7 segment display. For example if the remote input set to display hold then the bargraph will also be held whilst the 7 segment display value is held.

REC (analog retransmission operation mode) and **d: GOP** (digital output retransmission)

The following choices are available for analog or digital retransmission operation mode:

L, UE - live input mode. The retransmission will follow the electrical input and will not necessarily follow the 7 segment or bargraph display. For example if the remote input is set for peak hold operation

then when the remote input is closed the 7 segment display will only show the peak value but the retransmission will be free to change to follow the electrical input. This will be the normal setting used unless one of the special modes which follow is required.

P.HLd - peak hold mode. The 7 segment display and retransmission value will indicate the peak value only whilst the peak value function is operated via a contact closure on the remote input i.e. the 7 segment display and retransmission can rise but not fall whilst the remote input switch is closed. When the remote input switch is opened the retransmission value will remain fixed i.e. it will not rise or fall, although the 7 segment display value will be free to alter. This peak retransmission output can be cleared by closing the remote input switch for another operation or by removing power from the instrument. Note: In this mode the retransmission will show a zero reading until the remote input is operated for the first time after switch on.

d.HLd - display hold mode. The 7 segment display and retransmission value will be held whilst the remote input display hold switch is closed. When the switch is opened the retransmission value will remain fixed at the held value although the 7 segment display value will be free to alter. The held retransmission output can be cleared by closing the remote input switch for another operation or by removing power from the instrument. Note: In this mode the bargraph will show a zero reading until the remote input is operated for the first time.

H - peak (max.) memory mode. With the peak remote input switch open the retransmission will indicate the peak value in memory i.e. the retransmission output can rise but not fall. The retransmission output can be reset by clearing the memory. The memory may be cleared either by closing the remote input switch for approximately 2 seconds or by removing power to the instrument.

Lo - valley (min.) memory mode. With the valley remote input switch open the retransmission will indicate the valley (min.) value in memory i.e. the retransmission output can fall but not rise. The retransmission output can be reset by clearing the memory. The memory may be cleared either by closing the remote input switch for approximately 2 seconds or by removing power to the instrument.

d! SP - display mode. The retransmission output will follow whatever value is on the 7 segment display at the time.

Serial output functions - the following functions will be seen only with serial output option. Refer to the separate "PM4 Panel Meter Optional Output Addendum" booklet supplied when this option is fitted..

bAud (set baud rate).

Select from **300 . 600 . 1200 . 2400 . 4800 . 9600 . 19.2** or **38.4**.

Prty (set parity)

Select parity check to either **NONE**, **EVEN** or **odd**

Q.Pult (set RS232/485 interface mode).

Select **d! SP**, **Cont** or **POLL**

Allows user to select the RS232/485 interface operation as follows:-

d! SP Sends image data from the display without conversion to ASCII.

Cont Sends ASCII form of display data every time display is updated.

POLL Controlled by computer or PLC as host. Host sends ASCII command via RS232/485 and instrument responds as required.

̄.buS Modbus protocol

Addr (set unit address (0 to 31) for polled (**POLL** or **̄.buS**) mode).

Allows several units to operate on the same RS485 interface reporting on different areas etc. The host computer or PLC may poll each unit in turn supplying the appropriate address.

The unit address ranges from 0 to 31 (DEC) but is offset by 32 (DEC) to avoid clashing with ASCII special function characters (such as <STX> and <CR>). Therefore 32 (DEC) or 20 (HEX) is address 0, 42 (DEC) or 2A (HEX) addresses unit 10. **Note:** Address 0 cannot be used with Modbus protocol.

Returning to normal measure mode

When the calibration has been completed it is advisable to return the instrument to the normal mode (where calibration functions cannot be tampered with). To return to normal mode, turn off power to the instrument, wait a few seconds and then restore power.

Error Messages

The following details some of the instruments error messages.

- - - - - this message indicates that the input is open circuit or that the input type is incorrect. This could be caused by a broken wire, loose termination or a broken sensor. It could also indicate that the instrument is seeing an input which is out of its range, check that the **RETYPE** function selection matches the sensor being used.

SPAN Err - if this message is seen following an attempt at calibration it means that the input was below 10% of the full range of the sensor. Recalibrate using a higher temperature.

DEGRAD Err - if this message is seen following an attempt at calibration it means that change in temperature attempted is more than 10% outside the factory calibrated setting. It means that the change attempted is not considered valid and has not been accepted. This error message is used as a form of protection against large errors in the calibration procedure. Check that the correct sensor type has been selected and that the temperature measured by the reference thermometer during calibration was correct.

COP FAIL - this message indicates that the instrument power has been interrupted, usually due a spike on the power supply or signal input lines. The instrument will show this error message and then reset itself i.e. the "wake up" display messages will be seen after the **COP FAIL** message. Check the power supply and input lines for spikes, usually caused by something with a large inductance (e.g. solenoid, motor etc.) on the same supply circuit switching on or off. It may be necessary to suppress the interference at the source and/or place the PM4 on a different supply line.

-or- - this message indicates that the display is "overrange" i.e. it is being asked to display a number larger than its display range. e.g. larger than **9999** for a 4 digit instrument. Check also that the input scaling value used during calibration is correct. Also check that no stray voltages are present at the input. Use of a decimal point can also cause this error display e.g. if one decimal point is used then the

-or- error display will be seen if the temperature goes above 999.9 degrees. The use of the **DISP LIMIT** function (unless set to **NONE**) will also limit the maximum temperature which can be displayed before the **-or-** message is seen.

5 Function Table for fully optioned instrument

Initial display	Meaning of display	Next display	Default setting	Record your settings
RxLo	Alarm low setpoint value	Setpoint value or OFF	OFF	See following table
RxHi	Alarm high setpoint value	Setpoint value or OFF	OFF	See following table
RxHY	Alarm hysteresis	Hysteresis value in measured units	10	See following table
Rxtt	Alarm trip time	No of seconds before relay trips	0	See following table
Rxrt	Alarm reset time	No of seconds before relay resets	0	See following table
Rxn.o or Rxn.c	Alarm action N/O or N/C	Rxn.o or Rxn.c	Rxn.o	See following table
RxSP or Rxt i	Setpoint or trailing alarm	RxSP or Rxt i	RxSP	See following table
Rx OPEr	Alarm relay operation mode	Rx.AL , Rx.tP or Rx.Fr	Rx.AL	See following table
brgt	Digital display brightness	1 to 15 (15 = highest brightness)	15	
dULL	Remote brightness control	0 to 15 (15 = highest brightness)	1	
rEC-	Recorder output low limit	Value in memory	0	
rEC+	Recorder output high limit	Value in memory	100	
Functions below are accessible only via FUNC mode or if the ACCS function is set to ALL				
drnd	Display rounding - selects resolution	Value in memory	1	
dCPt	Display decimal point	0 or 0.1	0	
FLtr	Digital filter range 0 to 8	0 to 8 (8 =most filtering)	2	
rt d tYPE	Input sensor type	100 , 1000 , L335 or RS90	100	
dEG tYPE	°C or °F selection	°C or °F	°C	
di SP un, t	Units to appear on display	NONE , °C or °F	NONE	
rEC ctrl	Analog PI control on or OFF	on or OFF	OFF	
bAr-	Bar graph low reading	Value in memory	0	
bAr+	Bar graph high reading	Value in memory	100	
bAr tYPE	Bargraph operation mode	bAr , S.dot , d.dot or C.bAr	bAr	
d9.OP	Digital output type	b, n2 , b, n.b , 5CL or bcd	b, n2	
d9.OP	Digital output polarity	ALo or AHi	ALo	
bcd Strt	Start display (BCD mode)	Value in memory	0	
di 9-	Digital output - low reading (scaled binary mode)	Value in memory	0	
di 9+	Digital output - low reading (scaled binary mode)	Value in memory	1000	
CAL dEG	Temperature calibration	Live reading	n/a	
UCAL	Uncalibration	CAL CLr	n/a	
P.but	P button function	NONE , H , .Lo or H, Lo	NONE	
r. I NP	Remote input function	NONE , PHLd , d.HLd , H , .Lo , H, Lo , SP.AC , no.AC , CAL.S or dULL	NONE	
ACCS	Access mode	OFF , EASY , NONE or ALL	OFF	
SPAC	Setpoint access	R1 , R1-2 etc.	R1	
R1, R2 etc	Alarm operation mode	L , uE , P.HLd , d.HLd , H , .Lo or di SP	L, uE	

<i>REC</i>	Analog retransmission operation mode	<i>L, uE, P, HLd, d, HLd, H, .Lo</i> or <i>d! SP</i>	<i>L, uE</i>	
<i>d90P</i>	Digital retransmission operation mode	<i>L, uE, P, HLd, d, HLd, H, .Lo</i> or <i>d! SP</i>	<i>L, uE</i>	
<i>BAUD RATE</i>	Baud rate	<i>300, 600, 1200, 2400, 4800, 9600, 19.2 or 38.4</i>	<i>9600</i>	
<i>Prty</i>	Parity select	<i>NONE, EVEN or ODD</i>	<i>NONE</i>	
<i>D.Pkt</i>	Output, display, continuous, polled or Modbus	<i>d! SP, cont, POLL or n.bus</i>	<i>d! SP</i>	
<i>Addr</i>	Set unit address for <i>POLL</i> or <i>n.bus</i> mode	<i>0 to 31</i>	<i>0</i>	

Notes: The functions shown shaded are only seen when those options are fitted.
Refer to the appropriate appendix in this manual for PI relay control functions.

Settings for relays - record settings here							
	A1	A2	A3	A4	A5	A6	A7
<i>RxLo</i>							
<i>RxHi</i>							
<i>RxHY</i>							
<i>RxLt</i>							
<i>Rxrt</i>							
<i>Rxn.o</i> or <i>Rxn.c</i>							
<i>Rx.SP</i> or <i>Rx.t i</i>							
<i>Rx OPEF</i>							

6 Input/Output Configuration

If you need to dismantle the instrument to alter the input or output link setting configuration proceed as follows:

1. Remove the plug in terminals from the rear of the instrument

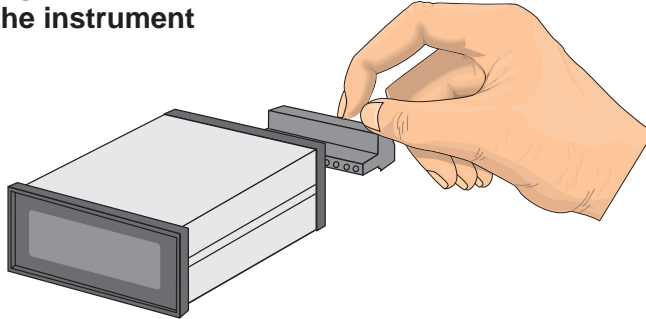

2. Remove 4 x self tapping screws from back cover, remove back cover by pulling it away from the instrument

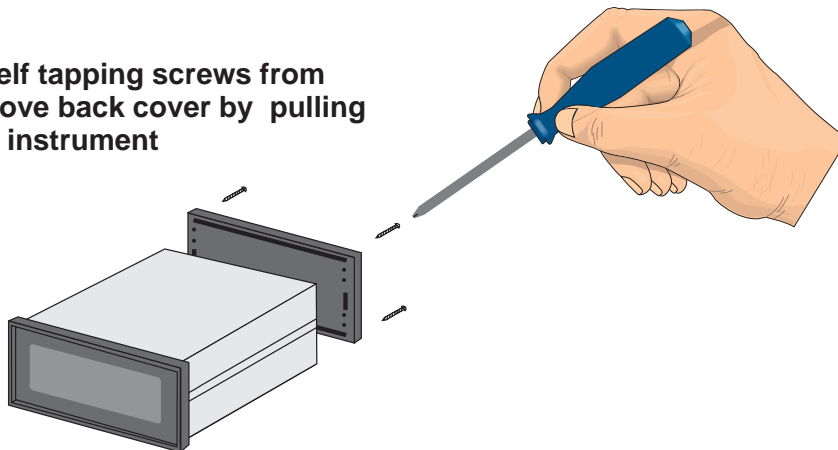

3. Using a screwdriver, remove the earth screw which passes through the case then slide out the board or boards

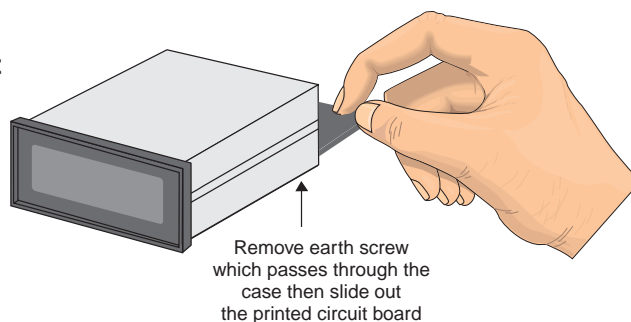

4. Configure the PCB links as required, see appropriate chapter
5. Slide PCB back into the case
6. Replace the earth screw which passes through the case
7. Refit back cover and fix with the self tapping screws
8. Plug the terminal strips back into the rear of the instrument

7 Specifications

Technical Specifications

Input Sensor Types:	100Ω RTD, 1000Ω RTD, LM335 and AD590
Temperature Range:	100Ω, -180 to 650°C & 1000Ω, -180 to 550°C LM335 & AD590 -50 to 150°C
ADC Resolution:	1 in 20,000
Accuracy:	0.1% when calibrated
Sample Rate:	4 per sec
Conversion Method:	Dual Slope ADC
Microprocessor:	MC68HC11 CMOS
Ambient Temperature:	LED -10 to 60°C, LCD -10 to 50°C
Humidity:	5 to 95% non condensing
Display:	LED Models 4 digit 20mm, 5 digit 14.2mm + status LEDs + 4 way keypad. 6 digit 14.2mm + 4 way keypad LED Bar Graph 20 segment bar + 4 digit 7.6mm LCD Model 4 digit 12.7mm
Power Supply:	AC 240V, 110V or 24V 50/60Hz DC 9 to 55V
Power Consumption:	AC supply 4 VA max, DC supply, contact supplier (depends on display type & options)
Output (standard):	1 x relay, Form, A rated 5A resistive
Relay Action:	Programmable N.O. or N.C.

Output Options

Extra Relays:	Same specs as Relay 1
Analog Retransmission:	4 to 20mA standard 0 to 1V or 0 to 10V link selectable
Serial Communications:	RS232 or RS485

Physical Characteristics

Bezel Size:	DIN 48mm x 96mm x 10mm
Case Size:	44mm x 91mm x 120mm behind face of panel
Panel Cut Out:	45mm x 92mm +1mm & - 0mm
Connections:	Plug in screw terminals (max 1.5mm wire)
Weight:	400 gms Basic model, 450 gms with option card

Appendix - Setting up the relay PI controller

PI control functions will only be seen if PI control software is fitted.

The Relay Proportional + Integral Controller can be made to operate in either pulse width control or frequency control mode via the **Rx OPEF** function. The best results are usually achieved by initially configuring as a “Proportional Only” controller and then introducing the Integral function when stable results are obtained.

The “x” in the **Rx OPEF** and other functions indicates the chosen relay i.e. for relay 1 the display will show **R1 OPEF**, **R1 ISP** etc. The **Rx OPEF** function allows three choices of operating mode for the chosen relay, namely **Rx.AL**, **Rx.tP** and **Rx.Fr**. If **Rx.AL** is selected the chosen relay will operate as a setpoint relay whose operation is controlled by the **RxLo**, **RxHi**, etc. settings and is not affected by any of the PI control settings. See the “Explanation of functions” chapter for details of operation when **Rx.AL** is selected. If **Rx.tP** is selected then the chosen relay will operate in pulse width control mode. If **Rx.Fr** is selected then the chosen relay will operate in the frequency control mode.

Pulse width control operates by controlling the on to off time ratio of the relay. In a typical application this would be used to control the length of time for which a dosing pump is switched on during a control cycle i.e. the pump or other device will continuously dose for the length of time the relay is activated and will stop dosing when the relay is de-activated.

Frequency control operates by changing the rate at which the relay switches on and off. In a typical control application the frequency control operation is particularly suited for use when one shot dosing is used i.e. the pump or other device puts out a fixed dosing quantity for every pulse received.

Pulse width modulation control mode

To use pulse width modulation control **Rx.tP** must be selected at the **Rx OPEF** function.

Pulse width control

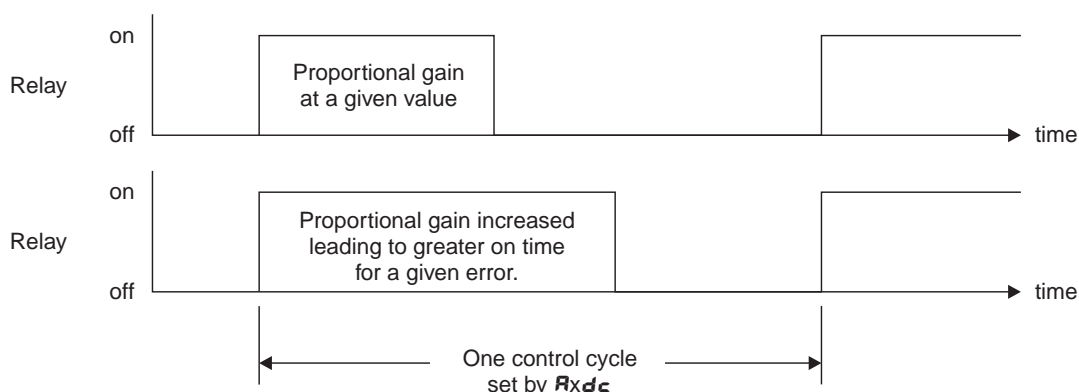

RxSP (control setpoint)

The control setpoint is set to the value in displayed engineering units required for control of the process. The controller will attempt to vary the control output to keep the process variable at the setpoint.

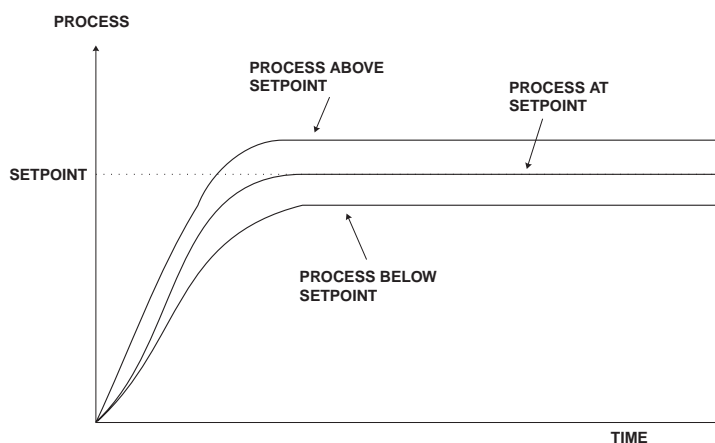

ctrl SPAN (proportional control span)

The function of the control span is to define the limit to which the proportional control values will relate. The control span value will be common to all control relays i.e. if more than one control relay output is being used then each of these relays operates from the same control span setting. The span value defines the range over which the input must change to cause a 100% change in the control output when the proportional gain is set to 1.000. This function affects the overall gain of the controller and is normally set to the process value limits that the controller requires for normal operation. For example if the control setpoint (AxSP) is 70.0 and the ctrl SPAN is 20.0 then an error of 20 degrees from the setpoint will cause a 100% change in proportional control output. For example with AxSP at 70.0, ctrl SPAN at 20.0, AxPG at 1.000 and AxBS at 0.000 a display reading of 68.0 or lower (AxSP minus ctrl SPAN) the control output will be at 100% i.e. the relay will be on continuously. The control output will then gradually adjust the on/off time as the display value reaches the setpoint.

AxPG (proportional gain)

The proportional value will determine the degree to which the controller will respond when there is a difference (error) between the measured value and the process setpoint. If the proportional gain is increased then for a given error the relay frequency will be increased i.e. the period of the control cycle will be decreased. The proportional gain action can be reversed by setting a negative gain i.e. with a negative gain the frequency will reduce as the error increases. With a proportional gain of 1.000 and an error of 10 or more (with control gain set at 10) the controller will increase the frequency by 100% if possible. With a proportional gain of 0.500 an error of 10 or more (with control gain set at 10) will cause the controller to increase the frequency by 50%, if possible.

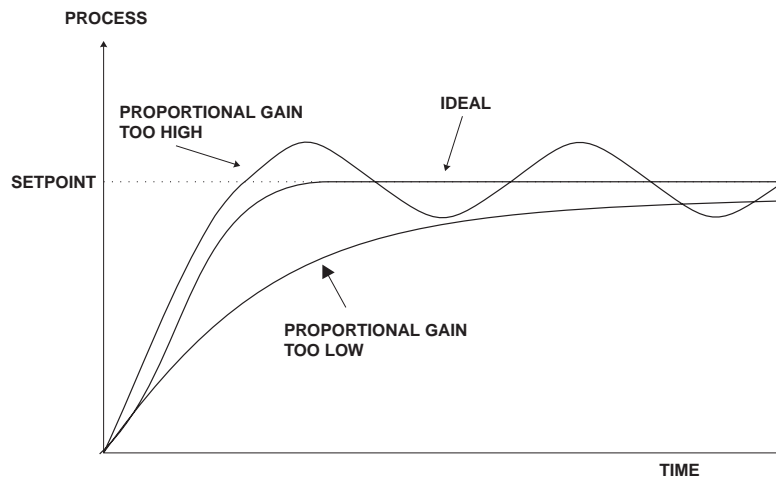

Too much proportional gain will result in instability due to excessive overshoot of the setpoint. Too little proportional gain will lead to a slow response.

AxI 9 (integral gain)

The Integral action will attempt to correct for any offset which the proportional control action is unable to correct (e.g. errors caused by changes in the process load). When the integral gain is correctly adjusted the control output is varied to maintain control by keeping the process variable at the same value as the control setpoint. Since the integral gain is time based the output will gradually increase if the error does not decrease i.e. if the measured value remains constant and there is an error (a difference between the measured value and the setpoint) then the frequency will be increased compared to the previous frequency output. The higher the proportional gain, the greater the degree by which the on to off ratio will be affected i.e. the response will be greater at higher integral gain settings. With an integral gain of 1.000 an error of 10 or more (with control span set at 10) will cause the integral action to try to correct at the rate of 100%/minute. With an integral gain of 0.200 an error of 10 or more will cause the integral action to try to correct at the rate of 20%/minute.

Too high an integral gain will result in instability. To low an integral gain will slow down the time taken to reach the setpoint. The optimum setting will depend on the lag time of the process and the other control settings. Start with a low figure (e.g. 0.200) and increase until a satisfactory response time is reached. The integral gain figure has units of gain/minute and may be set in the range of approx. 32.000 to -32.000. Note that a display with more than 5 digits is required to show -32.000. The integral action can be reversed by setting a negative gain figure, note that the sign of the integral gain must match the sign of the proportional gain.

The integral control output follows the formula:

$$\text{Integral control output} = \frac{\text{error} \times \text{Ig} \times \text{time (secs)}}{60} + \text{previous integral control output}$$

Where Ig is the integral gain set via **Ax: 9**.

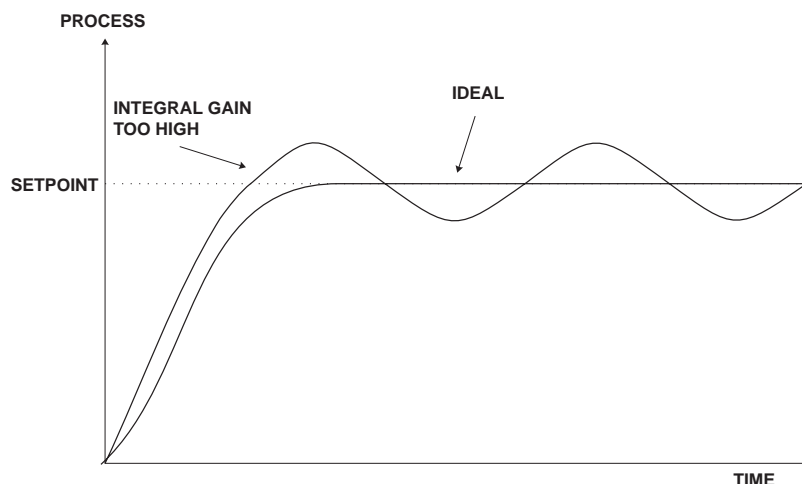

Ax: L (minimum limit of integral term)

The minimum limit can be used to reduce overshoot of the control setpoint when the control output is being reduced i.e. falling below the setpoint. The low limit reduces the available output swing by a percentage of the maximum output. Without a limit the integral output can be very large at the time the setpoint is reached and a large overshoot of the will then result. Settings available are from 0.0 to 100.0 (%). If the limit setting is too high then overshoot will result. If the setting is too low then the integral output can be limited to such an extent that the setpoint cannot be maintained. Start with a low value such as 20.0 and increase or decrease the value until a satisfactory result is obtained. The advantage of using separate low and high limits is that in many applications the response is very one directional e.g. the system may respond very quickly to a heat input but may cool down at a much slower rate. Separate high and low limit settings allow independent limiting of the integral control swing below and above the setpoint so a smaller minimum limit can be set to limit swings below the setpoint to compensate for the slower cooling time.

The minimum and maximum limits are used in conjunction with the output bias setting to maintain the control process setpoint value. For example with a bias (**Ax: 5**) set at 50%, minimum limit (**Ax: L**) set at 20% and a maximum limit of 30% the actual bias when the process is at the setpoint may be anywhere between 30% and 80% i.e. Integral control is being used to alter the bias setting in order to maintain the process at the setpoint. In this case the minimum term will allow the bias to drop to a value between 50% and 30% in order to maintain the setpoint. The maximum term will allow the bias point to rise to a value between 50% and 80% in order to maintain the setpoint.

Ax: H (maximum limit of integral term)

The maximum limit can be used to reduce overshoot of the control setpoint when the control output is increasing i.e. rising above the setpoint. Other than this the limit operates in the same manner as the low limit described previously.

Ax: 5 (control output bias)

The control bias sets the ideal steady state output required once the setpoint is reached. Settings are in % from 0.0 to 100.0. When set at 0.0 the relay will be de-activated for the entire control period when the measured input is at the setpoint (depending on proportional and integral gain settings). If set at 50.0 then the relay operation frequency will be lower than the maximum when the measured input is at the setpoint. If set at 100.0 then the relay will be at its maximum frequency when the measured input is at the setpoint.

Axdc (control cycle period)

Displays and sets the control period cycle from 0 to 250 seconds. The control period sets the total time for each on/off cycle. This time should be set as long as possible to reduce wear of the control relay and the controlling device.

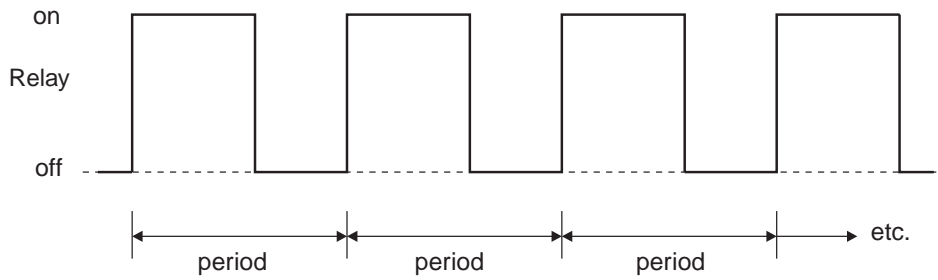

Setting up the pulse width controller

1. Set the **AxOPER** function to **AxLP**
2. Set the control setpoint **AxSP** to the required setting.
3. Set the control span **AxSPAN** to the required setting
4. Set the proportional gain **AxPG** to an arbitrary value e.g. **0.500**.
5. Set the integral gain **AxI G** to **0.000** (i.e. off).
6. Set the low and high integral **AxI L** and **AxI H** limits to an arbitrary value e.g. **20.00**
7. Set the bias **AxBS** to **50.0**.
8. Set the cycle **Axdc** period to 60 seconds.

Initialise the control system and monitor the control results. If the original settings causes process oscillations then gradually decrease the proportional gain until the oscillations decrease to an acceptable steady cycle. If the original settings do not cause process oscillations then gradually increase the proportional gain until a steady process cycling is observed.

Once the steady cycling state is achieved note the difference between the display value and the control setpoint value. Gradually increase or decrease the bias value until the displayed value matches (or cycles about) the control setpoint value.

Gradually increase the integral gain until the process begins to oscillate. Then reduce the integral gain slightly to regain the control without this added oscillation.

Create a step change to the process conditions and observe the control results. It may be necessary to fine tune the settings and use integral limits to obtain optimum results.

Set up sequence	Symptom	Solution
Proportional gain	Slow response	Increase Proportional gain
	High overshoot or oscillations	Decrease Proportional gain
Proportional bias	Process above or below control setpoint	Increase or decrease bias as required
Integral gain	Slow response	Increase Integral gain
	Instability or oscillations	Decrease Integral gain

Frequency modulation control mode

To use pulse width modulation control **Ax.Fr** must be selected at the **Ax OPEF** function.

Frequency control

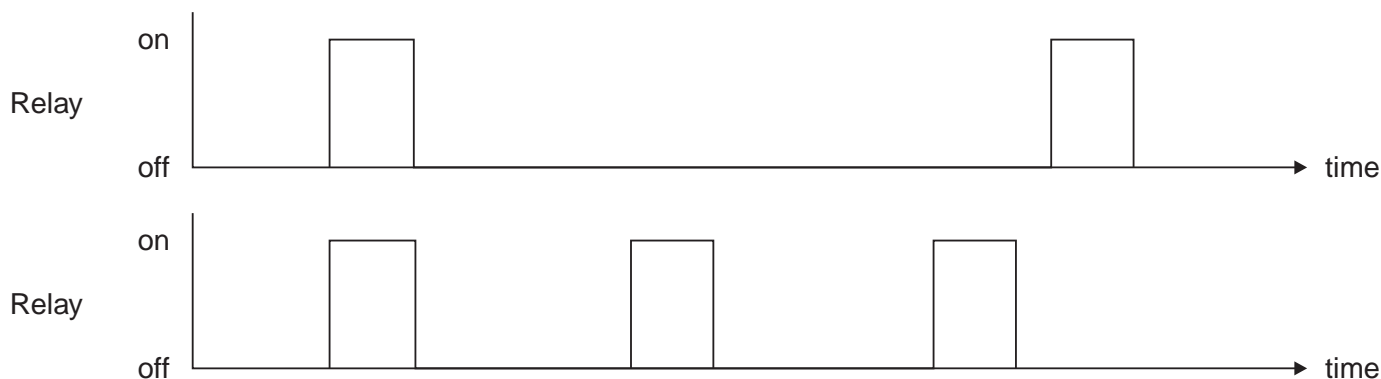

In frequency modulation mode the relay on time is fixed. A minimum relay off time can also be set. The control program will vary the actual off time to suit the error seen between the setpoint and the measured temperature at the time. For example if extra dosing is needed to reach the setpoint then the off time will be reduced resulting in more on pulses per period of time i.e. the frequency of the pulses is controlled to allow the setpoint to be maintained.

AxSP (control setpoint)

The control setpoint is set to the value in displayed engineering units required for control of the process. The controller will attempt to vary the control output to keep the process variable at the setpoint.

ctrl: SPAN (proportional control span)

The function of the control span is to define the limit to which the proportional control values will relate. The control span value will be common to all control relays i.e. if more than one control relay output is being used then each of these relays operates from the same control span setting. The span value defines the range over which the input must change to cause a 100% change in the control output when the proportional gain is set to 1.000. This function affects the overall gain of the controller and is normally set to the process value limits that the controller requires for normal operation. For example if the control setpoint (**AxSP**) is 70.0 and the **ctrl: SPAN** is 20.0 then an error of 20 degrees from the setpoint will cause a 100% change in proportional control output. For example with **AxSP** at 70.0, **ctrl: SPAN** at 20.0, **AxPS** at 1.000 and **AxBS** at 0.000 a display reading of 66.0 or lower (**AxSP** minus **ctrl: SPAN**) the control output will be at 100% i.e. the relay will be at its maximum frequency, this frequency will be determined by the **Axdr** and **Axdc** functions. The control output will then gradually adjust the off time as the display value reaches the setpoint.

AxPS (proportional gain)

The proportional value will determine the degree to which the controller will respond when there is a difference (error) between the measured value and the process setpoint. If the proportional gain is increased then for a given error the relay frequency will be increased i.e. the period of the control cycle will be decreased. The proportional gain action can be reversed by setting a negative gain i.e. with a negative gain the frequency will reduce as the error increases. With a proportional gain of 1.000 and an error of 10 or more (with control gain set at 10) the controller will increase the frequency by 100% if possible. With a proportional gain of 0.500 an error of 10 or more (with control gain set at 10) will cause the controller to increase the frequency by 50%, if possible.

Too much proportional gain will result in instability due to excessive overshoot of the setpoint. Too little proportional gain will lead to a slow response.

Axi I (integral gain)

The Integral action will attempt to correct for any offset which the proportional control action is unable to correct (e.g. errors caused by changes in the process load). When the integral gain is correctly adjusted the control output is varied to maintain control by keeping the process variable at the same value as the control setpoint. Since the integral gain is time based the output will gradually increase if the error does

not decrease i.e. if the measured value remains constant and there is an error (a difference between the measured value and the setpoint) then the frequency will be increased compared to the previous frequency output. The higher the proportional gain, the greater the degree by which the on to off ratio will be affected i.e. the response will be greater at higher integral gain settings. With an integral gain of 1.000 an error of 10 or more (with control span set at 10) will cause the integral action to try to correct at the rate of 100%/minute. With an integral gain of 0.200 an error of 10 or more will cause the integral action to try to correct at the rate of 20%/minute.

Too high an integral gain will result in instability. To low an integral gain will slow down the time taken to reach the setpoint. The optimum setting will depend on the lag time of the process and the other control settings. Start with a low figure (e.g. 0.200) and increase until a satisfactory response time is reached. The integral gain figure has units of gain/minute and may be set in the range of approx. 32.000 to -32.000. Note that a display with more than 5 digits is required to show **-32.000**. The integral action can be reversed by setting a negative gain figure, note that the sign of the integral gain must match the sign of the proportional gain.

The integral control output follows the formula:

$$\text{Integral control output} = \frac{\text{error} \times \text{Ig} \times \text{time}(\text{secs})}{60} + \text{previous integral control output}$$

Where Ig is the integral gain set via **RxI 9**.

RxI L (minimum limit of integral term)

The minimum limit can be used to reduce overshoot of the control setpoint when the control output is being reduced i.e. falling below the setpoint. The low limit reduces the available output swing by a percentage of the maximum output. Without a limit the integral output can be very large at the time the setpoint is reached and a large overshoot of the will then result. Settings available are from 0.0 to 100.0 (%). If the limit setting is too high then overshoot will result. If the setting is too low then the integral output can be limited to such an extent that the setpoint cannot be maintained. Start with a low value such as 20.0 and increase or decrease the value until a satisfactory result is obtained. The advantage of using separate low and high limits is that in many applications the response is very one directional e.g. the system may respond very quickly to a increasing but the system may take a long time to recover if the temperature setpoint is overshoot. Separate high and low limit settings allow independent limiting of the integral control swing below and above the setpoint.

RxI H (maximum limit of integral term)

The maximum limit can be used to reduce overshoot of the control setpoint when the control output is increasing i.e. rising above the setpoint. Other than this the limit operates in the same manner as the low limit described previously.

Rxb5 (control output bias)

The control bias sets the ideal steady state output required once the setpoint is reached. Settings are in % from 0.0 to 100.0. When set at 0.0 the relay will be de-activated for the entire control period when the measured input is at the setpoint (depending on proportional and integral gain settings). If set at 50.0 then the relay operation frequency will be lower then the maximum when the measured input is at the setpoint. If set at 100.0 then the relay will be at its maximum frequency when the measured input is at the setpoint.

RxdC (control relay minimum off time)

Displays and sets the control relay minimum off time from 0 to 250 seconds. If set to 0 the relay will be disabled. This time should be set as long as possible to reduce wear of the control relay and the controlling device. The control program can extend the off time to maintain the setpoint but not reduce it.

If a 100% error is seen then the pulse rate will be at its maximum i.e. the off time will equal **RxdC**. If a 50% error is seen there will be a pulse every 2 times **RxdC**. For a 25% error there will be a pulse every 4 times **RxdC** and for a 10% error there will be a pulse every 10 times **RxdC**.

RxdR (control relay on duration)

Displays and sets the control relay on duration from 0.0 to 25.0 seconds. If set to 0.0 the relay will be disabled. The duration should be long enough to ensure that the device being controlled receives an acceptable on pulse.

Setting up the frequency controller

1. Set the **Ax OPEF** function to **AxFr**
2. Set the control setpoint **AxSP** to the required setting.
3. Set the control span **ctr: SPAN** to the required setting.
4. Set the proportional gain to an arbitrary value e.g. **0.500**
5. Set the integral gain to **0.000** (i.e. off).
6. Set the high and low integral limits **AxI L** and **AxI H** to an arbitrary value e.g. **20.00**
7. Set the bias **AxbS** to **50.0**.
8. Set the minimum off time **Axdc** to **20**.
9. Set the relay on time **Axdr** to an arbitrary value e.g. **1.0**

Initialise the control system and monitor the control results. If the original settings causes process oscillations then gradually decrease the proportional gain until the oscillations decrease to an acceptable steady cycle. If the original settings do not cause process oscillations then gradually increase the proportional gain until a steady process cycling is observed.

Once the steady cycling state is achieved note the difference between the display value and the control setpoint value. Gradually increase or decrease the bias value until the displayed value matches (or cycles about) the control setpoint value.

Gradually increase the integral gain until the process begins to oscillate. Then reduce the integral gain slightly to regain the control without this added oscillation.

Create a step change to the process conditions and observe the control results. It may be necessary to fine tune the settings and use integral limits to obtain optimum results.

Set up sequence	Symptom	Solution
Proportional gain	Slow response	Increase Proportional gain
	High overshoot or oscillations	Decrease Proportional gain
Proportional bias	Process above or below control setpoint	Increase or decrease bias as required
Integral gain	Slow response	Increase Integral gain
	Instability or oscillations	Decrease Integral gain

Guarantee and Service

The product supplied with this manual is guaranteed against faulty workmanship for a period of 2 years from the date of dispatch.

Our obligation assumed under this guarantee is limited to the replacement of parts which, by our examination, are proved to be defective and have not been misused, carelessly handled, defaced or damaged due to incorrect installation. This guarantee is VOID where the unit has been opened, tampered with or if repairs have been made or attempted by anyone except an authorised representative of the manufacturing company.

Products for attention under guarantee (unless otherwise agreed) **must be returned to the manufacturer freight paid** and, if accepted for free repair, will be returned to the customers address in Australia free of charge.

When returning the product for service or repair a full description of the fault and the mode of operation used when the product failed must be given.

In any event the manufacturer has no other obligation or liability beyond replacement or repair of this product.

Modifications may be made to any existing or future models of the unit as it may deem necessary without incurring any obligation to incorporate such modifications in units previously sold or to which this guarantee may relate.

**This document is the property of
the instrument manufacturer
and may not be reproduced in whole or part without the
written consent of the manufacturer.**

This product is designed and manufactured in Australia.