

TH3-PH calibration procedure pH electrodes

View of transmitter and terminals
(with screw-on cover removed)

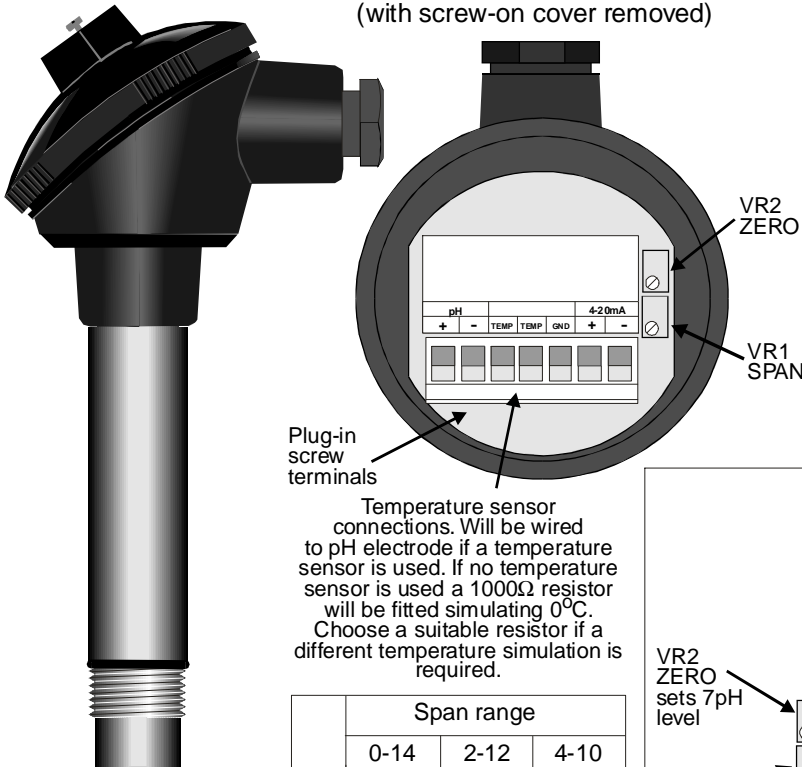

Temperature sensor connections. Will be wired to pH electrode if a temperature sensor is used. If no temperature sensor is used a 1000Ω resistor will be fitted simulating 0°C. Choose a suitable resistor if a different temperature simulation is required.

pH	Span range		
	0-14 mA	2-12 mA	4-10 mA
0	4.00	4.00	4.00
1	5.14	4.00	4.00
2	6.28	4.00	4.00
3	7.43	5.60	4.00
4	8.57	7.20	4.00
5	9.72	8.80	6.67
6	10.86	10.40	9.33
7	12.00	12.00	12.00
8	13.14	13.60	14.67
9	14.28	15.20	17.34
10	15.43	16.80	20.00
11	16.43	18.40	20.00
12	17.72	20.00	20.00
13	18.86	20.00	20.00
14	20.00	20.00	20.00

Transmitter specifications

Inputs: pH electrode
Pt1000 (1000Ω RTD) temperature sensor for automatic pH compensation or suitable resistor to simulate required temperature based on Pt1000 RTD.

Output: 2 wire 4-20mA loop powered
Adjustable 0-14pH to 4-10pH
Output must be symmetrical around 7pH e.g 0-14pH or 2-12pH etc.

Accuracy: Better than 0.25% of full scale when calibrated

Loop isolation: 100V DC or RMS
Protection: Reverse polarity protected
Loop supply: 15 to 36VDC
Ambient temperature: 0 to 60°C
Humidity: 5-95% non-condensing

Calibration procedure

Use 7 buffer or close to 7 buffer for the zero calibration input as the zero pot is used to adjust the 7pH output which should be 12mA.

The procedure for trimming the 4-20mA output is:

1. Ensure that the buffer solutions and probe are at the same ambient temperature. This may involve leaving them at the same location for a period of time e.g. 1 hour.

2. Place a mA meter in series with the 4-20mA loop.
3. Place the probe in the first buffer e.g. 7.0 pH
4. Adjust the ZERO potentiometer VR2 until the reading on the mA meter is the mA output required (see table for pH zero and span outputs).
5. Place the probe in the second buffer e.g. 4.00 pH.
6. Adjust the SPAN potentiometer VR1 until the reading on the mA meter is the mA output required (see table for pH zero and span outputs).
7. Repeat steps 3 to 5 until no further adjustment is needed i.e. until the mA outputs settle on the correct high and low values without any need for adjustment.

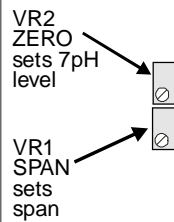

Wiring examples

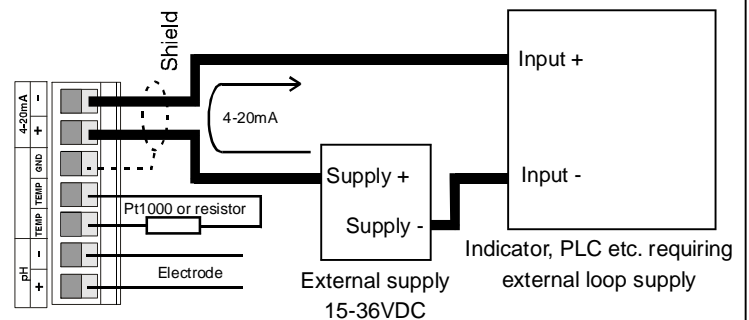
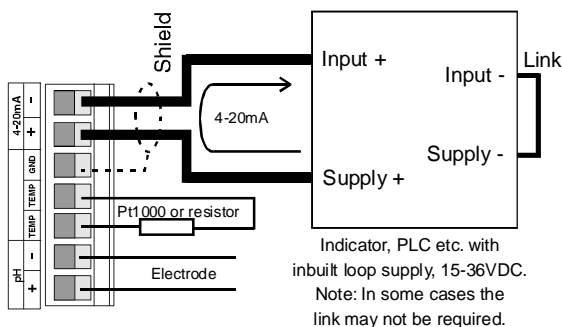

TH3PHCAL-1.4-0