

Application Note: Number AN12

Test circuit for PM4-WT & PM4-SG

The circuit below shows a simple test circuit which may be used to simulate a live input load to a PM4-WT or PM4-SG load cell monitor. The circuit should be used for basic testing only and should not be used to calibrate the display.

Resistor values given are nominal values but also represent the minimum values which should be used with an excitation voltage of 10V. If these resistor values are not available then choose the closest value obtainable which is larger than the values below. Fixed value resistors should preferably be metal film 0.1% type.

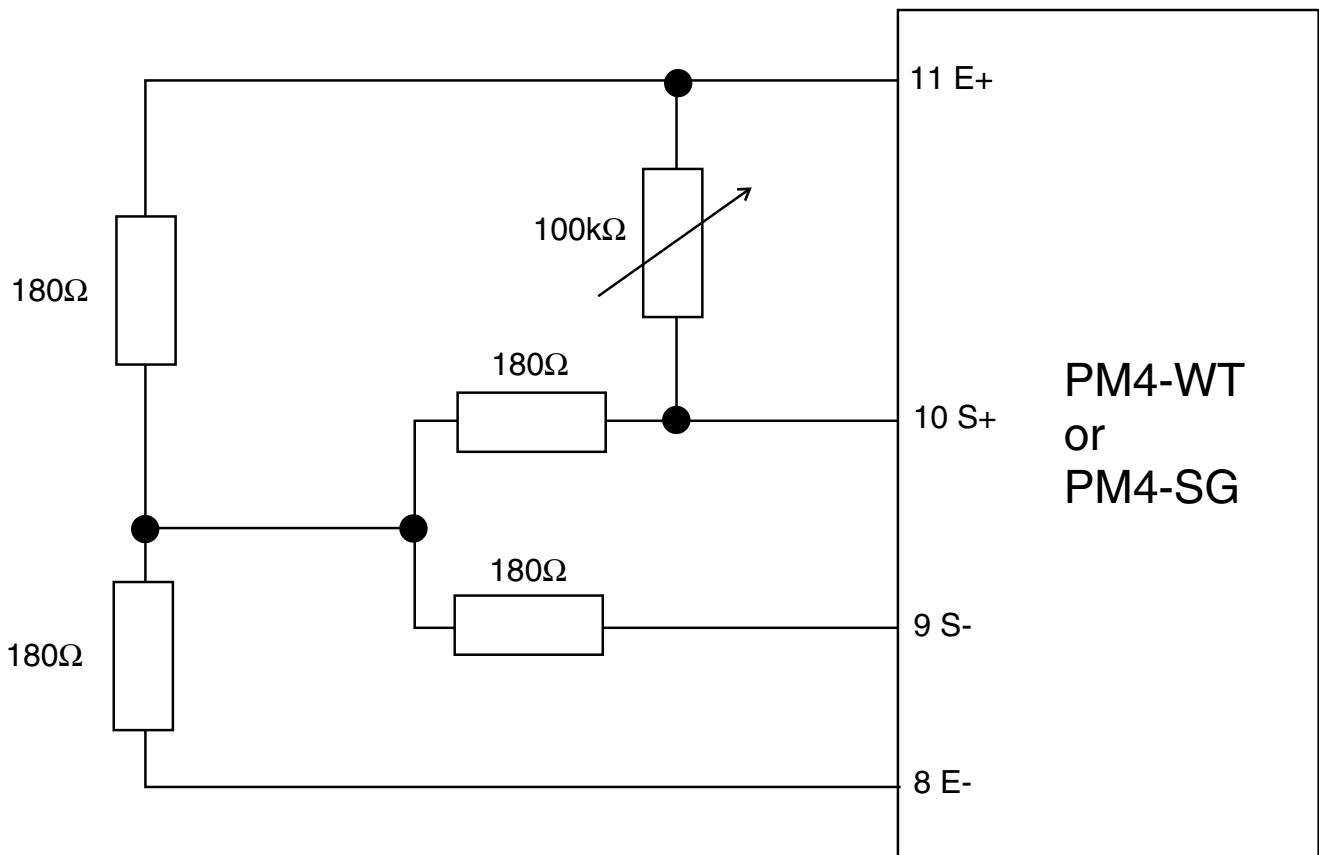

PMWTTTEST-1.0-1