

Large digit displays - 38, 45 or 57mm digit height models

LD-BC BCD, Binary or Gray Code input

The LD-BC large digit displays accept standard BCD, Binary or Gray Code input signals in either parallel (up to 16 bit), strobed or addressed modes. The displays are ideal for applications where load, pressure, weight, rate, temperature, position etc. indications need to be visible from a distance.

Special BCD operation modes allow certain non-numeric characters, e.g. \square , to be displayed for the non BCD characters 1010 to 1111.

In Binary mode the input may be up to 16 bit binary or 15 bits plus a strobe line. Active high or active low input data can be selected for BCD and binary inputs.

The instruments feature flexible pushbutton programming. Set up functions are easily adjusted using "on display" message prompts. This allows functions such as decimal point position, display brightness, operation mode etc. to be easily set.

Display



4 digit 57mm high LED (visibility to 25m)
See separate brochures for 100 and 200mm versions

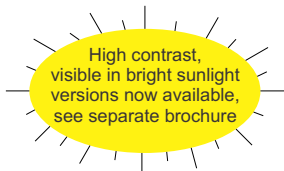

Features

- Selectable as BCD, Binary or Gray code
- Wide range of signal input levels (up to 48V - input level required is factory configured)
- Parallel, strobed or addressed inputs
- 4 x 57mm LED - visibility rating to 25m
- IP65 rated wall mount enclosure
- Panel mount kit available
- Pushbutton setup and calibration
- Remote inputs can be configured to one of a wide range of functions including zero, tare, peak hold, etc.
- Programmable digital filter
- Two setpoint relays optionally available (5A, 240VAC max.)
- RS232 or RS485 serial communications optionally available
- The auto-brightness feature for LED displays varies the display brightness to suit the ambient light
- 2 year guarantee
- See separate brochures for 100mm and 200mm display models

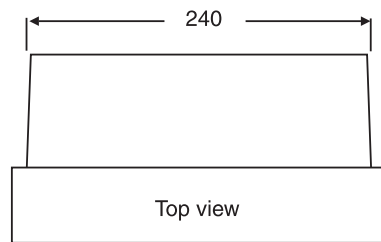
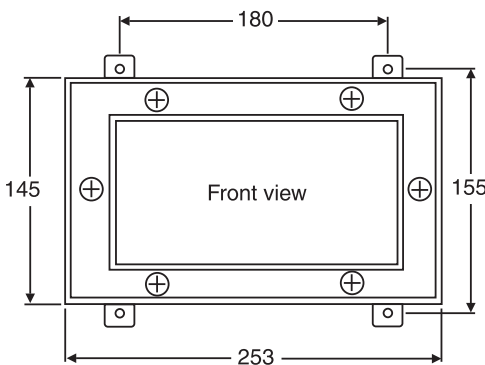

All dimensions in mm

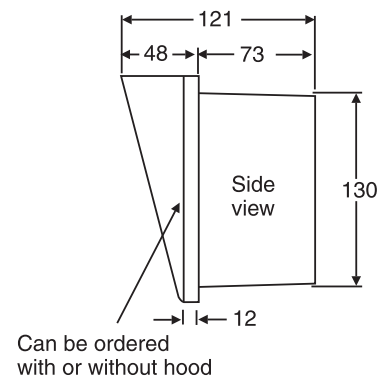

LDBC57-3.6-0

AMALGAMATED INSTRUMENT CO PTY LTD

ACN: 001 589 439

Unit 5, 28 Leighton Place Hornsby
NSW 2077 Australia

Telephone: +61 2 9476 2244
Facsimile: +61 2 9476 2902

e-mail: sales@aicpl.com.au
Internet: www.aicpl.com.au

Specifications

Input types	Up to 16 bit parallel binary, BCD or Gray Code Parallel Strobed or addressed Special "scaled" input mode Special "weighted" binary input
Input levels	Voltage free switch contact closure or 0 to 5VDC or 0 to 12-24VDC or 0 to 24-48VDC signal (factory configured)
Input logic	High or low selectable
Decimal point	Use selectable or selectable via remote inputs for BCD inputs
Microprocessor	MC68HC11 CMOS
Ambient temperature	-10°C to 60°C
Humidity	5% to 95%
Weight:	1.3kg
Power Supply	See order code table (type is factory configured)
Power Consumption	AC supply: 15VA max, DC supply: depends on supply voltage, typically 500mA (2A peak) for 24VDC using non isolated DC supply

Panel mounting

The instrument is provided with removable surface (e.g.wall) mounting tabs mounting. A panel mount kit is optionally available which allows the instrument to be mounted in a panel cut out. If required the instrument can be optionally supplied with the front hood removed to allow a more flush panel mount fitting.

Part number for panel mount kit: LD-MTG-PM-KIT

Part number for hood removal: LD-HOOD-REMOVAL

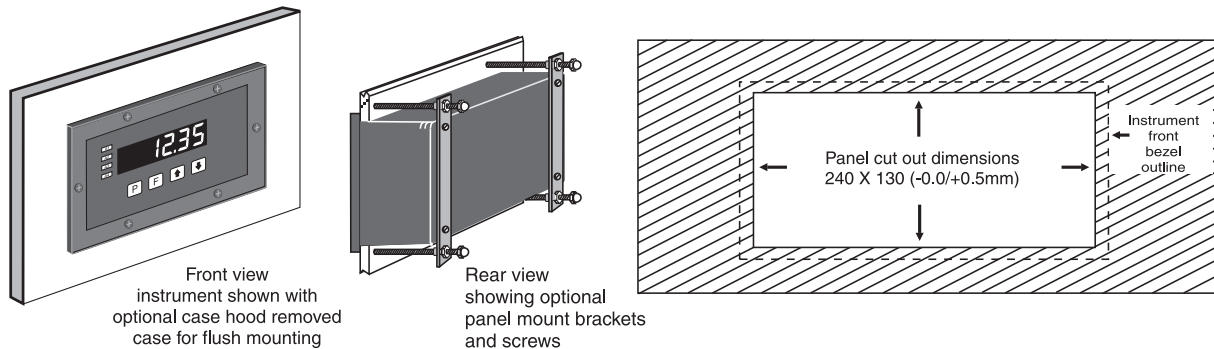

LD-BC order codes for 57mm displays

The last section is for optional outputs (if required). Optional outputs are factory configured.

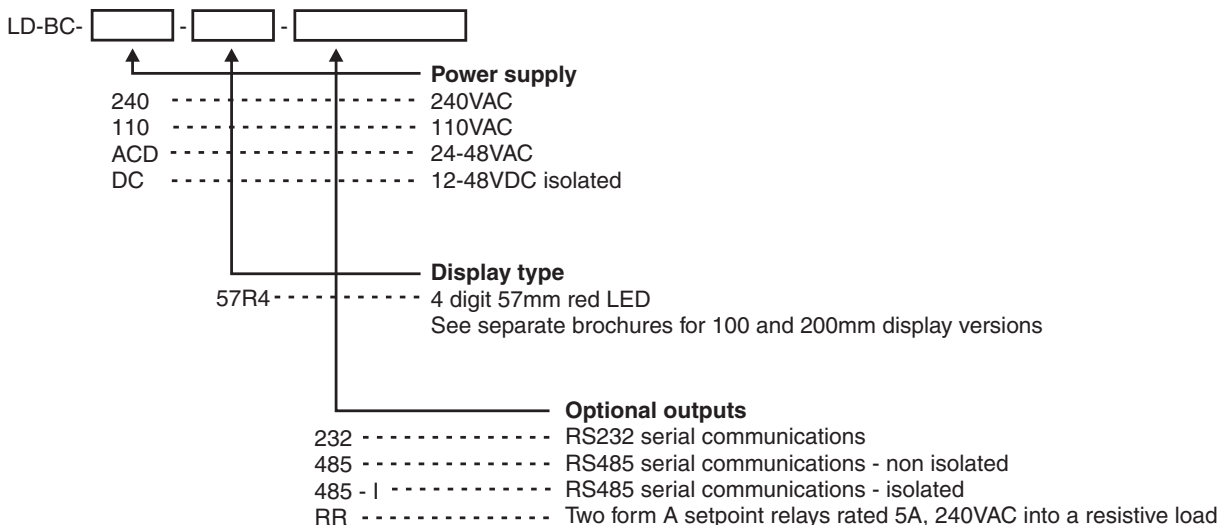

LDBC57-3.6-0

AMALGAMATED INSTRUMENT CO PTY LTD

ACN: 001 589 439

Unit 5, 28 Leighton Place Hornsby
NSW 2077 Australia

Telephone: +61 2 9476 2244
Facsimile: +61 2 9476 2902

e-mail: sales@aicpl.com.au
Internet: www.aicpl.com.au